

PIONEERING

BY
" GILCRAFT "

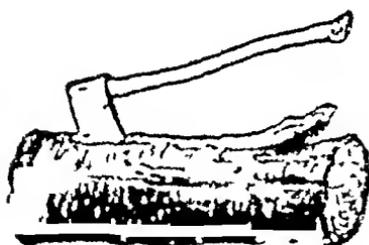

C ARTHUR PEARSON LTD.

Tower House

Southampton Street, London, W.C.2

*First published with the title
"Preparing the Way Pioneering" 1931*
Second Edition 1933
Third Edition 1942
Fourth Edition 1943

CONTENTS

HOW TO USE THIS BOOK

GLOSSARY

CHAPTER

I	THE "WHYS" OF THE MATTER	9
II.	CORDAGE AND ROPES	13
III	LASHINGS AND SLINGS	19
IV	MOVING HEAVY WEIGHTS AND TRAINING A ROPE	27
V	ANCHORAGES AND SHEER-LEGS	34
VI	RAFTS	39
VII.	ROPEWAYS	47
VIII	SIMPLE AND LIGHT BRIDGES	54
IX	TRESTLE AND LOCK BRIDGES	60
X	FLAGSTAFFS, SIGNALLING MASTS AND TOWERS	67
XI	CLIMBING AND TREE-TOP SHELTERS	76
XII	CAMP SHELTERS	83
XIII	DISPLAYS AND RALLIES	89
XIV	INSTRUCTIONAL MODELS	94
XV	THE PIONEER'S TOOLS	100
XVI	USING AN AXE	105
XVII	BUILDING A LOG CABIN	109
XVIII	THE RESULTS	120
	INDEX	123

HOW TO USE THIS BOOK

PERHAPS first it would be as well to say how *not* to use this book.

Don't attempt to read it right through, you will get muddled and possibly frightened at the number of things described. After you have read the first chapter, to get the point of view you must keep *reading and practice* in step with each other, in other words—when you have read about something, *e.g.* whipping, DO THAT before you go on to the next item.

The simplest plan to follow is to take the various Scout Badges which include pioneering tests in the order of simplicity, *i.e.* from Tenderfoot upwards. This means selecting from each chapter the bit which applies to the particular badge. It is not necessary to know all about bridges as set down in Chapters VIII and IX before making, for example, a shelter or flagstaff.

Here is a suggested scheme

Tenderfoot—Whipping, pp 17-18

Second Class—Lashings square, pp 19-20, diagonal, p 20
Axemanship hand axe, pp 103-105, knife, p 103

First Class—Sheer lashing, p 21
Axemanship, Chapter XVI

The next step would be the *Pioneer Badge*. This can be planned as follows

Axemanship—Chapter XVI

Knots—Marline hitch, pp 23-24

Lashings—Pp 18-22

Model—Chapter XIV for a general description of the process, then select a simple light pole bridge, pp 57-59, or a single lock trestle bridge, pp 61, 66

Raft—Chapter VI, select one suited to available materials

Shelter—Chapter XII, select the easiest to make from local materials

Once you have worked through some such scheme as the above, you will have laid a good foundation for tackling anything else in the book which takes your fancy.

The great thing to remember is to pick and choose according to your needs and the materials you have to work with. All the time *let reading go hand-in-hand with practice*.

Finally remember that the Index is there for your convenience when you want to look up some point in a hurry.

GLOSSARY

- ADZE** A cutting tool with a blade at right angles to the handle
- AFT** Towards or at the stern of a vessel, hence—behind
- ANCHORAGE** A fixed post round which a rope can be tied, and which will take a heavy weight or strain
- AUGER** A carpenter's tool used for boring holes in wood
- BEND, TO** To fasten a rope to another rope or some other object
- BIGHT** A loop in a rope
- BILLHOOK** A thick, heavy knife with a hooked end, used for chopping brushwood
- BLOCK** A piece of wood or metal containing one or more wheels or pulleys on which a rope can run
- BLOCKS AND TACKLE** Two blocks, through which one continuous rope has been taken, so as to form an apparatus for lifting weights, straining a rope, etc
- BRACE** A spar connecting two others to give support and strength
- BRACE AND BIT** A tool used by carpenters for boring holes
- BRUSHWOOD** A thicket, underwood, loppings of branches
- BUTT** The larger end of a spar
- CAULK, TO** To stuff the seams (usually of a ship)
- CHOCK, CHOCK-A-BLOCK** When two blocks come as close as possible
- CORDAGE** A collective term for ropes, usually referring to cords and lines less than one inch in circumference
- COURSE** A row or tier of bricks, stones, or logs in a building
- CROSS-TREE** A nautical term for timbers lashed to the tops of masts to support rigging, etc
- DERRICK** A single mast, or post, used for hoisting weights
- FALL** The rope rove in a tackle
- FORE, FORWARD** In front
- FRAPPING TURNS** Turns of a rope taken at right angles to the others to tighten a lashing
- FREE END** The end of the rope which is free to work with
- GAFF** A spar lashed across a mast, usually to support a sail
- GUY** A rope to steady a load in hoisting, or to act as a stay
- GYN** An apparatus consisting of three spars lashed in a tripod, used for hoisting weights
- HAFT** The wooden handle of an axe
- HALYARDS** A rope for hoisting or lowering yards, sails, flags
- HEEL** The butt, or thick end of a spar
- HEW, TO** To cut with an axe
- HEWING AND SCORING** Smoothing the face of a log by cutting with an axe
- HITCH** A species of knot by which a rope is bent to a hook, spar, or other rope, does not hold its position by itself
- HOLDFAST** An anchorage

- JOIST** One of a series of parallel horizontal timbers to which floor boards or the laths of a ceiling are nailed
- KNOT** The intertwining of a rope, etc., so as to fasten one part to another part of the rope, etc., or to another object
- LASH, TO** To fasten or bind with a rope or cord
- LASHING** A rope or cord by which anything is secured (See Fig 3)
- LEDGER** A horizontal spar across the bottom of the legs of a trestle
- MARLINE-SPIKE** A pointed iron pin for opening the strands of rope in splicing
- MAUL** A heavy wooden hammer
- MOUSE, TO, MOUSING** To close the mouth of a hook with cord
- PARBUCKLE** A double sling usually made by passing the two ends of a rope under the object to be moved
- PICKET** A pointed stake, post, or peg
- PORT** The left-hand side as one looks forward
- PURLIN** A horizontal timber resting on the principal rafters and supporting the boards on which the roof is laid (See Fig 74)
- REEVE, TO** To pass a rope through a block
- SADDLE** A piece of sacking placed above a lashing to protect it from being frayed
- SCORE, TO** To make a cut in a log
- SCORING AND HEWING** Smoothing the face of a log by cutting with an axe
- SHAKES** Same as shingles, but some three feet in length
- SHEERS, SHEER-LEGS** An apparatus consisting of two spars secured at the top for hoisting heavy weights or to act as a support
- SHINGLES** Thin tiles of wood
- SISAL** A kind of hemp, a cordage used for light lashings
- SLING** A band, loop, or other arrangement of rope for suspending, hoisting, or transferring anything
- SNATCH-BLOCK** A single block with an opening in one side to take the bight of a rope (See Fig 17)
- SPAR** A pole, or piece of round timber
- STARBOARD** The right-hand side as one looks forward
- STOP, TO** To tie down the coils of a rope
- STROP** A ring of rope used to secure a hook to an anchorage
- TACKLE** An apparatus of blocks and rope for lifting, hoisting, or pulling
- TIE-BEAMS** A horizontal beam connecting rafters (See Fig 73)
- TIP** The point or thin end of a spar
- TRANSOM** A horizontal spar across the top of the legs of a trestle (See Fig 42)
- TRESTLE** An open braced framework of timber for supporting the horizontal portion of a bridge, etc (See Fig 42)
- TRUSS** A kind of trestle supporting and strengthening the structure in a roof (See Fig 73)
- WIND-BREAK** A rude shelter erected to keep off wind and rain from one direction
- YARD-ARM** A spar slung horizontally or slantwise on a mast

PIONEERING

CHAPTER I

THE "WHYS" OF THE MATTER

"Pioneers are men who go ahead to open up a way in the jungles or elsewhere for those coming after them" (*Scouting for Boys*)

THIS is the sentence with which B-P opens his Camp Fire Yarn on the subject of Pioneering. He then goes on to talk about knot-tying, hut-building, felling trees, bridging and so on.

So it is that Scouts with any pretensions of living up to that name must be ready to go out in advance and prepare the way for those who follow after. This is true of all our Scout work, all of us—men, women and boys—are training ourselves to set an example, to give a lead, to others, not only in the things that we do, but also by what we are.

This is a sternly practical book, but it is necessary in the beginning of it to give reasons why B-P should suggest pioneering practices as part of the training of the Boy Scout, and to point out to Scouters the value of such practices in their training of their Scouts. It is best to give you this in his own words, and then to expand these in one or two details.

In a letter dealing with this particular book B-P wrote "I should be inclined to suggest to Scouters that in addition to the technical details of knotting, lashing, anchorages, etc., there is an educative value in pioneering since it gives elementary training in stresses, mensuration, etc., and also develops initiative, resourcefulness and so on out of local material. It also gives practice in team work and discipline."

The Scoutmaster's efforts should be chiefly directed to the training of the character of his Scouts. This is the primary job of all Scouters, whatever their position in the Movement and with whatever section of it they deal. Many of us are, however, inclined to neglect some of the useful means which we have to second our efforts. Sometimes we look at certain practices suggested in *Scouting for Boys* as unnecessary, uninteresting or even foolish. We ourselves have not much of an inclination in that direction, and so we turn away from such

suggestions, forgetting that it is our duty to examine them not through our own selfish eyes, but through the eyes of our boys, be they young or old, just growing out of childhood or growing into manhood

It will be found, therefore, that the various pioneering practices suggested in the succeeding chapters are not only interesting to Scouts and Rover Scouts, but that they have a peculiar educative value of their own, and that they can assist to further the formation of character in Scouters themselves as well as in Scouts and Rover Scouts

If a pioneering job is taken in hand, it will soon be found that observation has to be used in order to ascertain exactly what is necessary to be done and what materials are available or can be procured in order to do it Initiative and ingenuity are frequently required here Then care has to be taken in the immediate preparations for the job This applies not only to the collection of the gear, but to any measurements that may be required, to calculations of weights to be borne, of breaking strains, etc

As soon as the work is taken in hand it will quickly become apparent that there must be one person in definite charge, whose word is obeyed implicitly, otherwise damage and danger may result Just as quickly it becomes obvious that each one on the job must know what part of it he is to do and get on with it In other words, team work and leadership are emphasised as not only valuable but essential Very quickly, too, do those engaged on the job find that deeds, not words, are required, the worker comes into his own, and the talker who holds the stage all too frequently at other times is elbowed to the side

One learns also the truth of the maxim "more haste less speed" and realises the value of patience and the necessity for making a thorough job of a lashing, say, instead of just trusting to luck As B-P says "To tie a knot seems to be a simple thing, and yet there are right ways and wrong ways of doing it, and Scouts ought to know the right way Very often it may happen that lives depend on a knot being properly tied"

These, and many other lessons, are learnt very quickly and thoroughly when we come to tackle any real pioneering job

There is another side to the picture, too The Scout must be a practical kind of fellow, he must be able to do things, he must be able to do things which are useful, he must be able to do things out of doors as well as indoors Here are a whole heap of practices to help in the "doing" of things Some will

THE "WHYS" OF THE MATTER

argue that such things cannot be of much use to the Scout in the future since he is not going to be a soldier or a pioneer or even an engineer, but will in future work in an office or shop. This is quite immaterial, he may not, it is true, have any need to build a bridge or erect a tower in his future work, but the very building of such a bridge or tower will give him practice and ability to tackle other jobs. He is being fitted out to be self-reliant, to tackle anything with a high heart, no matter how impossible it may seem at first, and his practice in pioneering will stand him in very good stead and he will be thankful for it in the future, just as he will be thankful for the fun and delight of it in the present.

So far we have been talking of somewhat indefinite, but by no means problematical, values; now let us turn to more definite values in the training of the Scout as such. Scouting aims to secure an all-round development of body, mind and spirit. Herein are exercises which will undoubtedly help in the development of the first two, and, I verily believe, in the third in some small part as well. Healthy exercise of body and mind leading to the satisfaction of a job completed cannot fail to have an influence on the spirit of a growing boy or growing man. The continued insistence on the value of these practices for Rover Scouts is purposeful, for they can do the same sort of things as Scouts, but in bigger ways and with heavier material, and they will get the same kind of value and enjoyment out of it.

The training of the Scout should be a continual and progressive development, starting from the Tenderfoot Tests and working up to something really big. So far as pioneering is concerned, the training of almost the majority of Scouts in this subject of pioneering begins and ends with the learning of their tenderfoot knots. Many excuses are advanced for this, but they are excuses, not reasons. There is not much about it in *Scouting for Boys* we do not know anything about such things our boys are not keen on them: we can't get hold of the materials we haven't got places over which to build bridges it's an awful fag and a waste of time anyway.

It is true that not many practices in pioneering are described in *Scouting for Boys*, but it is a book of suggestions, not a manual, yet if all our Troops did practise the suggestions given, we should not be so badly off.

It is not necessary for the Scoutmaster to know every branch of Scouting, it is not possible either; but he can look round for other people who may know something of such things and press them into his service. He can also pick up a few ideas

and additional suggestions from training courses, and now he will have a book to help him too, if he will only translate the word into action

Boys cannot possibly be keen in advance on things which they know nothing about, and of which they have not heard. No normal boy once he has done a little elementary pioneering of the real open-air kind will be other than keen on it. The building of huts and roadways is a trait handed down to us from our forbears.

Materials are not so difficult to come by as is imagined, and in any case it is good for us to have to exercise a certain amount of ingenuity. It is wonderful what a number of kindly people there are in the world if we approach them in the right way, and builders and such like people have proved no exception. We can work wonders with even our Scout staffs and a ball of sisal—which, being translated, means a certain kind of cord.

Bridges can be built on dry land if absolutely necessary, although they are obviously not so romantic or so adventurous as when built over a stream or ditch. If we have practised at home over imaginary streams, we can soon find the real article if we go out for an expedition or go to camp. As in the case of materials it is merely a question of "where there's a will, there's a way."

We have seen already that such practices as these cannot be regarded as a waste of time, and so frequently the crux of the whole question lies in the fact that the Scoutmaster does regard such departures from his ordinary routine as a fag, and, to avoid trouble to himself, he denies his boys undoubted advantages and undoubted pleasures.

If any Scout Troop makes up its mind that it is going to include the subject of pioneering amongst its normal activities, half its difficulties disappear at once.

A start can be made indoors with staffs and sisal, as already suggested. Lashings can be learnt, trestles built, and the elementary theories of stresses and strains appreciated. Talks on pioneers and bridge builders will thrill as well as instruct. Inter-Patrol competitions in the use of the staff will exercise the initiative and imagination of Patrol Leaders. A local Troop rule that so many knots and lashings are added to the normal second-class and first-class tests will quickly carry knotting from the tenderfoot stage into the eyes and use of the practical First Class Scout. In such ways as these the ground is prepared and the proper attitude of mind founded.

These beginnings can be carried further out of doors whenever the opportunity offers. The clearing of paths, repairs of

CORDAGE AND ROPES

hedges and railings, making of camp gadgets, erection of camp fireplaces and ovens—these are all pioneering jobs and to be recognised as such. Gradually, but surely, comes the desire to attempt more ambitious, and even more spectacular, jobs, and here is where the Troop will learn most from its own mistakes. The first real pioneering job tackled will not as a rule be successful—it is rather unfortunate if it is—mistakes will be made, possibly tempers will be frayed. If the Troop becomes discouraged in consequence then harm will be done, but the tactful Scoutmaster will know just what to apply in the way of encouragement so that his Scouts, realising their deficiencies and lack of ability, will still be determined to persevere, and the foundation of real good pioneering will have been laid.

But this is quite sufficient introduction to our subject, so let us cut the talk and get on to the job!

CHAPTER II

CORDAGE AND ROPES

“We had no rope with us in West Africa, so we used the strong creeping plants, and also used thin withes or long whippy sticks, which we made still more pliant or bendable by holding one end under foot and twisting the other round and round with our hands” (*Scouting for Boys*)

FOR pioneering purposes of all kinds the use of cords and ropes is essential, and the proper selection of these and the proper construction of a knot or lashing is a matter of very great importance, since an insecure lashing, a wrong knot, or a rope which will not carry the strain demanded of it may involve considerable risk of accident.

Working with Scouts especially it is obvious that we must take every care and precaution to see that the materials we use are sound and that any risk is minimised as much as possible. At the same time we should certainly not avoid pioneering practices because there may be a certain amount of risk involved in them. To do so would be to defeat the Scout object of training boys to be self-reliant and to be prepared to deal with emergencies. What we have to do is to see the dangers, guard against them in all possible ways, teach our boys where such dangers lie, and train them to overcome them.

So it is that, if we are going to start off to practise pioneering with our Troops or with our Crews, we must have some general knowledge of the types, strengths and care of ropes to begin with.

PIONEERING

Cordage and rope, such as we will normally use, are made chiefly from sisal or manila hemp, the former coming from Mexico and the latter from the Philippine Islands. Cotton, coir, or other vegetable yarns are also used, while rope is also made of wire, but we will practically always confine our attention to hemp ropes and cordage. These are built up in this way. Yarn is made by twisting fibres together, thread by twisting together two or more small yarns, string is made in the same way as thread, using slightly larger yarns, cord by twisting together several threads. Two or more large yarns twisted together form a strand, several strands twisted together form a rope.

The Lay of Ropes

If a rope is held up, it will be noticed usually that the strands run from the bottom left hand to the top right hand. The twisting of the strands together is called the lay, and, in this case, the rope is known as right-handed. Three strands laid up together right-handed form a hawser-laid rope. Four strands laid up right-handed, sometimes round a heart or core, form a shroud-laid rope. Three hawser-laid ropes laid up together left-handed form a cable-laid rope. A hawser-laid rope is the strongest type, cable-laid and shroud-laid ropes being one-fifth weaker size for size. On the Continent of Europe hawser-laid and shroud-laid ropes are, more frequently than not, laid left-handed. That, however, only causes complications when it comes to splicing, and does not materially affect the use of the ropes for knotting and lashing and normal pioneering purposes.

Measurement of Ropes

Ropes are measured and described by their circumferences in inches, a "three-inch" rope being just under an inch in diameter. The word "rope" is not usually applied to anything less than one inch in circumference, smaller sizes being described as cord, line and so on. Cords are usually distinguished by the number of yarns—six, nine, twelve, etc.

Taking Out Kinks

In making rope the aim is to make the tension on the strands and on the yarns composing the strands equal. But, since this is impossible, it is always necessary to take out the "turns" in a new rope for the first two or three days it is used. If a new rope is so kinky that it cannot be used, the twist can be removed by dragging it backwards and forwards along the ground. The

CORDAGE AND ROPES

method used at sea to take the turns out of a coil of new rope is to coil it down *left-handed*; the end is then passed through the coil and hauled through. If this is done three or four times, the kinks will have been taken out evenly from the whole length of the rope.

Strength of Rope

Roughly the *safe* working load for hemp ropes, which are stronger and more durable than cotton, may be taken as being equal in cwts to the square of the circumference in inches, so that the safe working load for a 3-inch rope would be 9 cwts. Ropes which have been in use for some considerable time should not be subjected to more than two-thirds of the safe working load for new ropes. These figures do, however, allow of considerable margin and represent about one-seventh of the actual *breaking* load.

Weakening Effect of Knots

Knots, turns and hitches weaken a rope by forming a bend which distributes the strain on the fibres unequally. For instance, it has been calculated that an eye splice weakens a rope by 10 per cent, a short splice by 20 per cent, a timber hitch by 35 per cent, a clove hitch or running bowline by 40 per cent, a reef knot or sheetbend by 50 per cent, and an overhand knot by 55 per cent.

Care of Rope

All ropes and cordage should be kept as dry as possible, and should not be coiled or put away when damp or they will become mildewed very quickly. Mildew usually causes a defect which will only become apparent when the rope suddenly breaks. Wet ropes should be laid in the shade to dry, or be hung up under cover and allowed to remain hanging until quite dry, before being coiled up. A stiff and hard rope is likely to cause trouble, especially if it is to be run through a block. It can be softened and be made pliable by placing it in water and bringing the water to the boil. After this the rope should be stretched straight until it is thoroughly dry. This process weakens the strength of the rope, but not very appreciably.

Coiling Ropes

A rope should always be coiled in the direction of its lay; thus, a hawser- or shroud-laid rope (*i.e.* right-handed) should be coiled clock-wise, or with the sun, and a cable-laid rope (*i.e.* left-handed) counter-clock-wise. When coiling a right-

handed rope on the ground, stand with your back towards the rope and bring the end round in front of you from the right—some people prefer to pull the rope through between their legs. With the rope describe a circle in front of you on the ground, but be careful not to make too large a one, working clockwise. Distribute coil upon coil evenly, steadying with your foot if necessary. When the rope has been coiled up, bind the coils together in three places, each one-third way round the circumference of your circle, with a piece of sisal or string knotted with a reef or slippery-reef.

Lashings, or short lengths of light rope or of cord, can be coiled by taking turns round the thumb and elbow of left arm. The end can be secured by making a half-hitch with it round one end of the hank thus formed. Possibly a better way is to pick up the end of the lashing with the right hand, palm up, and pull the rope through the left hand, palm down, to the full extent of the arms. Then bring the hands together and place that part of the lashing held in the left hand into the palm of the right hand, forming a right-handed loop. This process can then be repeated until all the rope is coiled. If the rope has a tendency to kink, a slight twist of the rope between the finger and thumb of the left hand in the requisite direction will correct such a tendency. To secure the coil pull out an inside turn, wind the turn round the top of the coil, and pass it through the middle of the coils between its own turn and the top. This will form a secure loop by which the coil can be hung up.

Storing Ropes

All ropes and lashings should be carefully coiled before being put away. Heavy ropes of some length are best laid flat on a shelf or hung on a stout hook, and should be labelled with their size, length and—possibly—use. Lashings should be sorted out into lengths and all those of the same length placed in a sack suspended from a hook or beam. The sack should be labelled carefully, the number and length of lashings contained in it being noted. A set of stencil letters and figures is of great help in marking. Careful storage will not only keep one's ropes and other gear in order, but will save considerable expenditure of time when the materials for any particular pioneering job are required. A special bag should be kept for light lashings and odd lengths of sisal.

Re-laying a Rope

After ropes have been in use for some time, or if the ends of them have not been properly secured, it sometimes happens

that the strands become untwisted and need re-laying. The process is shown in Fig 1. The rope is held firmly in the left hand at the point from which the re-laying is to start. Strand 1 is then twisted up tightly by turning the right hand as indicated by the arrow round the wrist. This strand is then pulled down into its place in the rope, and is held there by the left thumb, the rope itself being still grasped firmly in the left hand. Strand 2 is then grasped, pulled across the rope, twisted tightly, and laid firmly in place above strand 1. It is held in position by the left thumb which does not move round the rope but straight up it on the same side. Strand 3 is similarly treated. This process is repeated until the end of the rope is reached, and should result in the return of the rope to its original condition. If the strands themselves are badly untwisted, it is better to cut off that portion of the rope than to try to re-lay it.

A Sailmaker's Whipping

It is essential that the ends of all lashings and ropes used for pioneering should be properly secured to prevent fraying and untwisting, and before being put away all ends should be inspected and made secure. This can be done by splicing or by whipping, but since lashing and

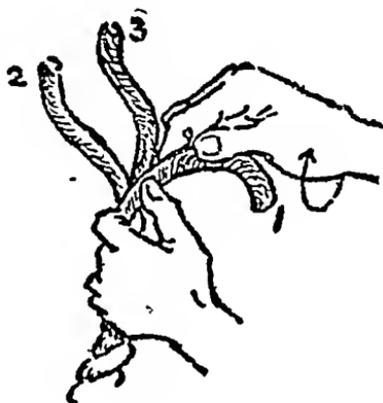

Fig 1

blocks and tackle enter so much into pioneering it is frequently best to put a secure whipping on the ends rather than double the circumference of a rope by a back-splice. It must be remembered, however, that as a permanency a back-splice is much superior and more useful for thicker and longer ropes.

An easy, and at the same time secure, whipping is that known as the Sailmaker's, and is strongly recommended for general use.

Unlay the end of the rope two or three inches and separate the strands. Take your length of whipping material—strong yarn sometimes known as "sailmaker's yarn" is best, and place a loop of this over one strand, bringing the ends out between the other two strands (Fig 2). Re-lay the rope, and wind the long end of the whipping round and round the rope in the usual way until a sufficient number of turns have been taken. The secret of successful whipping is to pull each turn just as hard as the yarn will stand, and lay all turns as close together as possible. Keeping the strain on the yarn, slip the

loop back over the end of the strand it surrounds, and pull it as tight as possible by pulling on the short, unused end. Finally bring the end up so that it "serves" the third strand and tie both ends firmly together between the ends of the strands with a reef knot. The ends of the whipping should then be cut off close to the knot, and the loose strands cut neatly off about a quarter of an inch from the end of the whipping. The whipping, if properly done, should withstand all ordinary wear and tear.

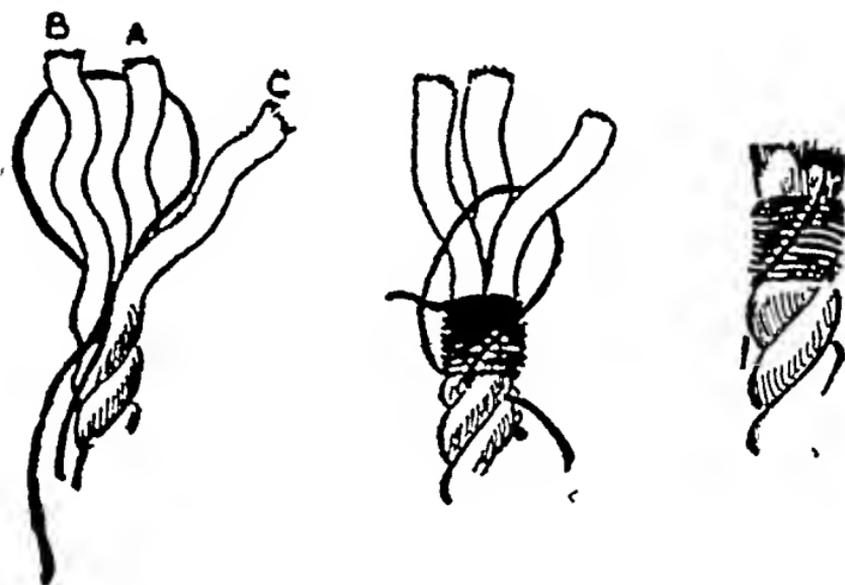

Fig 2

If the yarn is waxed with soap, candle fat or beeswax, it works better and makes a much better job of the whipping.

Lengths of Lashings

Frequently difficulty is experienced in completing a lashing owing to the rope used not being long enough. It is advisable, therefore, to know beforehand the length of lashing required for different types of timber. If lashings are cut to these lengths, properly whipped and stored in separate bags according to their length, a great deal of subsequent trouble is saved. The colour of the whipping at the ends of the lashings can easily be used as a guide to their length. Sailmaker's yarn can be dyed for this purpose, or "Macramé" twine, which is sold in different colours and weights, used instead of the yarn.

The lengths of lashings depend mostly on the size of the spars to be lashed. As a rough working rule the diameter of the

LASHINGS AND SLINGS

spar in inches gives the length of the lashing required in fathoms. Only the figure-of-eight lashing requires a longer length.

A fathom is roughly the amount of rope that a full-grown man could measure and pass out with outstretched arms, and is now taken to equal 6 feet.

CHAPTER III

LASHINGS AND SLINGS

"They were quite useless for building bridges, as this had to be done by tying poles together" (*Scouting for Boys*)

LASHINGS enter so constantly into all forms of Scout pioneering, bridging, trestle making, building towers and shelters, that it is necessary to describe the common lashings used here, despite the fact that they are already described in *Knotting*. It will be necessary also to repeat instructions in regard to holdfasts, and one or two other items, but it is not intended to repeat descriptions of knots, except in the case of one or two very important ones.

Lashings are used whenever it is required to lash together staffs, poles or spars, either parallel to, in continuation of, or at right angles to, each other. There are four types of lashing used for varying purposes—square, diagonal, sheer, figure-of-eight.

The Square Lashing

A square lashing is used whenever spars cross each other at an angle, and touch each other at the point where they cross. The lashing starts with a clove hitch round the upright spar immediately below the point where the other spar crosses it. The free end and the standing part of the rope are then twisted tightly round each other, after the clove hitch has been forcibly tightened, in order that the hitch may hold firm. The lashing is then taken in front of, and over the second spar, the clove hitch being placed at the angle nearest the take off on to the second spar (Fig 3). The lashing then passes behind the upright spar and down in front of the second spar, and finally round behind the upright spar immediately above the original clove hitch.

The process is then repeated four times, keeping outside the previous turn on the horizontal, or second, spar and inside them on the upright, or first, spar. The lashing is strained at

each turn by using a half hitch (see p 23) 'round an ordinary mallet. A couple of frapping turns are then taken round the lashing between the spars, strained well, and the lashing is finished off with a clove hitch round the end of the horizontal spar. Great care should be taken to see that this clove hitch is pulled well into the corner from which the rope takes off. Any spare rope should be wound round a convenient spar and secured with a series of half hitches or marline hitches.

During the construction of the lashing the turns should be well beaten together, so that a thorough tight lashing is the

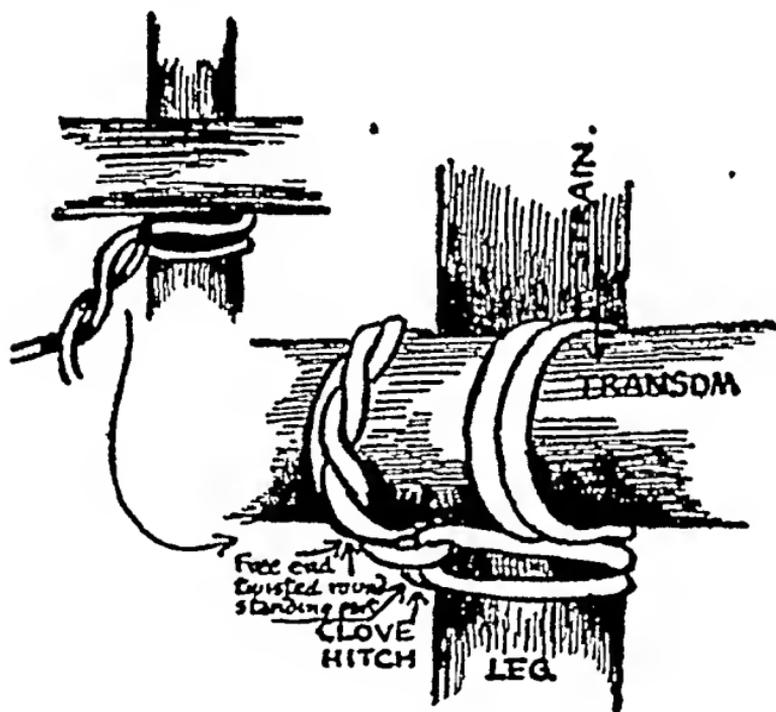

Fig 3

result. The test of a good lashing is both its neatness and its firmness, and slovenly, loose work should not be allowed, even if time is short. The golden rule to observe is—never hurry a lashing.

The Diagonal Lashing

A diagonal lashing is used to "spring" two parts together, that is to lash together two spars which tend to spring apart, and not touch, when they cross. This is the case where the diagonal braces of a square trestle (see p 62) cross each other. The lashing is started with a timber hitch round both spars on which a purchase is taken so as to draw the two spars together.

Three or four turns of the lashing are then taken round one fork, and three or four turns round the other fork. A couple of frapping turns are taken, as before, to tighten up the turns, and the lashing is finished off with a clove hitch round the most convenient spar

The Sheer Lashing

A sheer lashing (this is frequently spelt "shear," and is also known as a round lashing) is used to lash together two parallel spars or ropes, or two spars which will be opened out in order to form sheer-legs (see p 36), or which are being lashed end to end in order to make, say, a flagstaff. This lashing is usually started with a clove hitch round two of the spars, but sometimes, if the two spars are not to be opened out, the clove hitch is placed round both spars, or a timber hitch round both spars is used. As in other lashings the free end and standing part are twisted round each other. Seven or eight turns are then taken round both spars. If the spars are to be lashed parallel to each other for strength, or if the spars are to be used as sheer-legs, then a couple of frapping turns are taken, and the lashing finished off with a clove hitch on the opposite spar. In sheer-legs the starting clove hitch will be below the lashing on one leg, and the finishing clove hitch above the lashing on the other leg. If, however, two staffs, say, are being lashed together in order to make a flagstaff, not only will two lashings be required (Fig 4), but it is best to omit the frapping turns and tighten up the lashing with wedges, since the closer the staffs can be brought together the better. These wedges can be just pointed or sharpened pieces of wood, nothing elaborate is necessary.

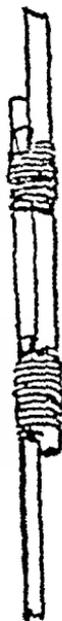

Fig 4

The Figure-of-eight Lashing

A figure-of-eight lashing is used at the tops of three poles together in order to form a tripod or "gyn". The three spars are laid together so that the end of the centre spar points in the opposite direction to the ends of the outer spars. The lashing starts with a clove hitch round one of the outside spars at a reasonable distance from the end, six or seven turns are then taken quite loosely round the spars, working under and over alternately (Fig 5), like a figure-of-eight, it is finished off with loose frapping turns and a clove hitch as in the sheer

lashing If this lashing is made too tight it will not be possible to bring the legs to form an equilateral triangle on the ground

Here is another and quicker way of lashing poles together in order to form a tripod, if the tripod is not to be used for supporting heavy weights Hold the poles in a vertical position, butts on the ground Lay the end of the lashing along one of the poles and tightly wrap the other end three or four times round the poles, winding from the top downwards and

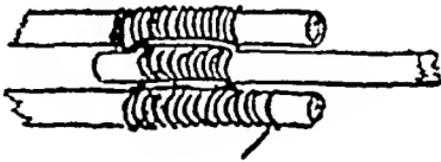

Fig 5

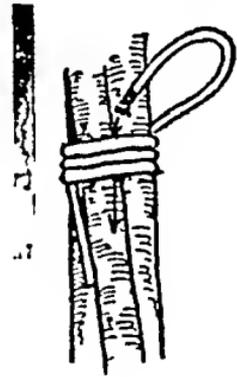

Fig 6

binding the first end laid against the pole Now carry the free end upward over the wrappings, and then downward underneath the wrappings as shown in Fig 6 Pull this end down and jamb it tight between the wrappings and one of the poles When the butts of the poles are spread this lashing will hold firm

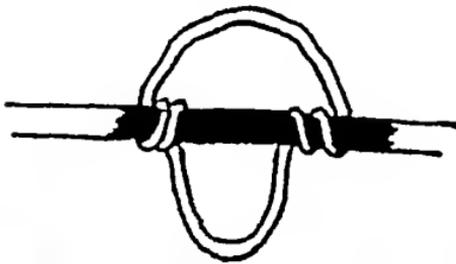

Fig 7

Lashing a Block to a Spar

Begin with a clove hitch round the spar above the block, take the lashing two or three times round the spar and the hook of the block, and finish off with a clove hitch round the spar below the block

Another method is to use a strop—an endless rope formed by means of a short splice This is passed round the spar and through its own bight, the purchase on the block keeping the strop in place If the spar is not very thick, or if it is desired to secure a

block to a rope, a longer strop is used—known as a selvagee strop The middle of the selvagee is placed against the rope, and cross turns taken until the bights come

LASHINGS AND SLINGS

together, when the hook of the block is put through them (Fig 7)

To Make a Selvagee

Drive two nails into a plank the necessary distance apart, according to the length of strop required. Make the end of the yarn fast to one of the nails, and pass a dozen or more turns round both nails until the strop is the required strength and thickness. Great care must be taken to see that every turn is quite taut and equal. Secure the turns together with a series of marline hitches.

The Marline Hitch

In addition to finishing off a selvagee, a marline hitch is used (i) to put a temporary seizing on two or more ropes—seizing means to bind them together—as in finishing off the lashing on a 3-2-1 holdfast (see p 34), (ii) to lash together a number of sticks or Scout staffs into a bundle for convenience of transport; (iii) to lash up hammocks, long rolls of canvas, etc

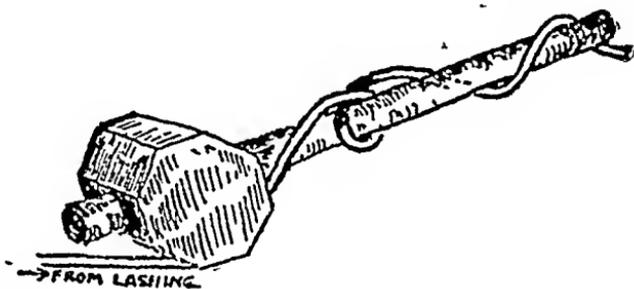

Fig 8

A marline hitch is really a "simple" or "over-hand" knot. The difference between a marline hitch and a half hitch should be noted, the former jamb and stay where they are put, the latter do not unless close together, or the rope's end is secured or kept strained.

Setting up a Strain

To set up a strain use a half hitch with a turn or two around mallet, staff or other implement (Fig 8), as already mentioned in tightening up a lashing.

To Secure a Rope to a Hook

There are various ways of securing a rope to a hook whether for purposes of suspension or of taking a strain with blocks and tackle, etc.

The usual way adopted is to make a catspaw, in the *middle* of a rope this is made by throwing back a bight in the rope, then taking hold of the two smaller bights now formed in

PIONEERING

hand and twisting them up separately, and finally placing the hook in the two eyes thus formed. A catspaw at the end of a rope should, however, be made in a different way. A loop is made and laid over the standing part so as to form two bights, the standing part is rolled round these three or four times and the bights twisted once or twice before the hook is inserted into them (Fig 9)

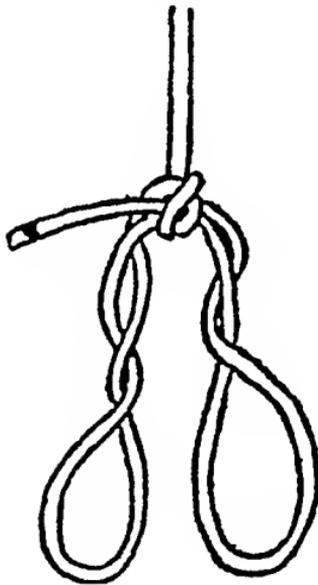

Fig 9

are not illustrated here, but descriptions of them will be found in *Knotting*, if required

Slings

For the suspension or transportation of heavy objects some kind of sling is necessary, and various methods are used to serve different purposes. For slinging sacks or tents, or casks in a horizontal position, all that is required is a long strop, or a non-slip loop made by a bowline. (If weights or strains are heavy, what is known as a water-bowline (Fig 10) is preferable to an ordinary bowline, as it will not jam so tight.) Spread the loop out into an oval, lay the sack across it, pass one end of the loop through the other and over the hook (Fig 11)

A barrel sling is used in order to sling a cask or barrel in an upright position. Stretch the rope on the floor, and place the cask on end on it so that the free end of the rope is about twice the length of the cask. Bring the free end and the standing part of the rope up over the top of the cask, and there make a simple or overhand knot. Open this knot out

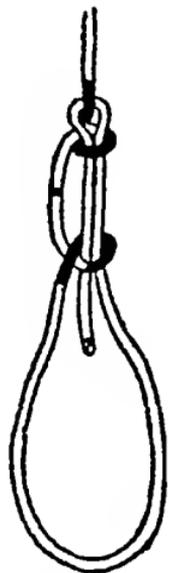

Fig 10

LASHINGS AND SLINGS

and pass the two sides of it over the respective sides of the cask. Finally tie the free end to the standing part with a bowline over the top of the cask (Fig 12)

The Boatswain's Chair

When it is necessary for a person to be suspended (not by the neck—there is a hangman's knot for that purpose!) over the side of a building or boat or on a mast for painting or repairs, or to be transported over an aerial runway (see p 48), a boat-

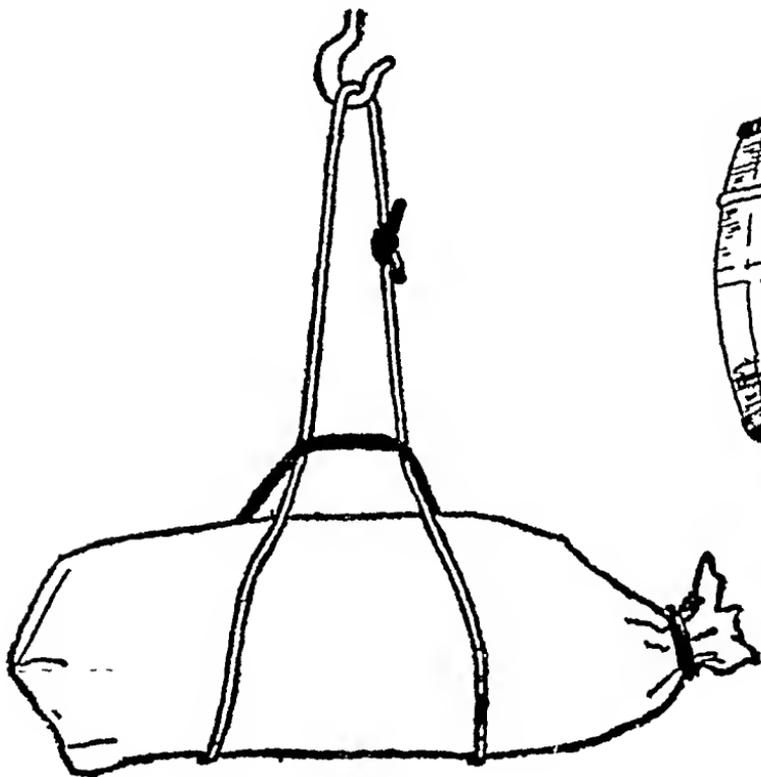

Fig 11

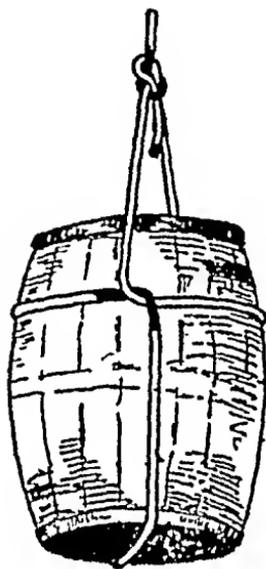

Fig 12

swain's—or more commonly bosun's—chair is used. Different hitches are used for this purpose and are suitable for the suspension of all kinds of planks where a hanging staging is required.

A marline-spike hitch can be used, the end of the plank taking the position occupied by the marline-spike. More frequently a clove hitch is employed; make a clove hitch of ample size, so that when placed over the end of the plank it will hang loosely below it; upset the clove hitch by drawing

the right-hand rope to the left and the left-hand to the right (Fig 13), turn the plank over, draw the ends up over and attach the short end to the longer with a bowline Attach a

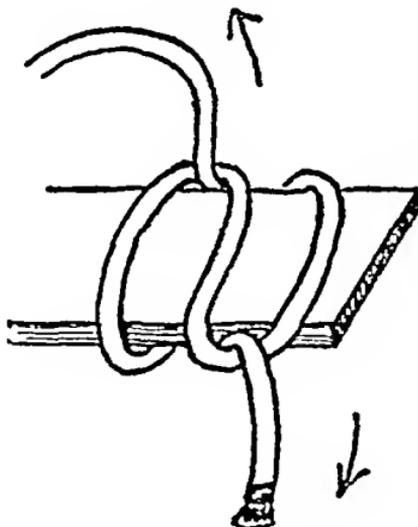

Fig 13

second rope to the other end of the plank in the same way, and the chair is ready

Probably the best method, however, is to make use of the

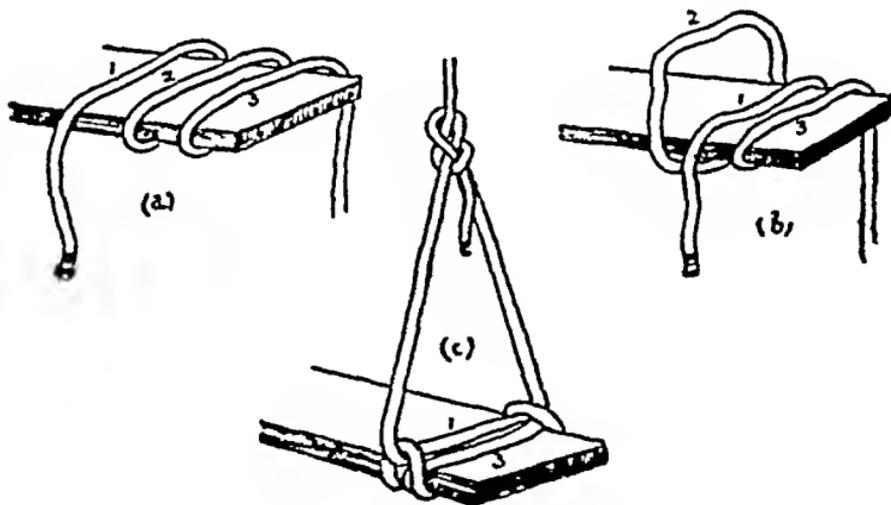

Fig 14

scaffold hitch Lay the short end of the rope over the plank, leaving enough hanging down to tie to the long rope finally Wrap the long end loosely twice round the plank (Fig 14 a)

Carry rope 1 over rope 2 and place it between 2 and 3 (14 b). Carry rope 2 over ropes 1 and 3 and over the end of the plank. Take up the slack by drawing on the two ends of the rope, and join the short end at a convenient distance above the plank to the longer with a bowline (14 c)

The scaffold hitch can also be used for securing a bundle of sticks or poles together.

CHAPTER IV

MOVING HEAVY WEIGHTS AND STRAINING A ROPE

“ We also did what we could to improve the road ” (*Scouting for Boys*)

IN clearing the ground for permanent camp sites, or for other purposes, it is frequently necessary to move heavy weights like logs, stones, etc., and a knowledge of the various ways in which to move such objects is essential to the pioneer. If we are working with Scouts, we have to be particularly careful to see that no undue strain is placed on them in the moving or lifting of weights. Even if we are working with Rover Scouts, we have to exercise care for the same reason. In point of fact the clearing of fallen logs and boulders is best apportioned to Rover Scouts and not Scouts; it is, however, true pioneering work, and should be appreciated as such.

The Lever.

We often wonder how it is that, without modern machinery, cranes, winches, and so on, the Egyptians were able to move the huge blocks of stone of which the Pyramids are built, or the ancient Druids were able to lift the stones that form Stonehenge. It is probable that the only mechanical aid that the builders of Stonehenge had was the lever, which works on the same principle as the child's see-saw. When levers are used for moving logs, or prising out boulders, care must be taken to see that they are strong enough to stand the strain that is to be placed upon them. If levers are being used to lift anything from the ground, one man should be detailed to slip a roller or solid block under the object as soon as it is raised, so that those on the levers do not have to take the strain for longer than is absolutely necessary. For instance, when a large log is being sawn through cross-cut saw, it is frequently necessary to raise the low point where it is being sawn in order to prevent the

jamming It is always advisable to do this before the cut is started, and not to leave it until the saw starts to stick.

The use of levers to roll logs is a comparatively simple business, but there is a special instrument, called a cant-hook (Fig 15), which is made for this purpose. These cost about 15s a-piece, but they are well worth the money if there is a lot of log-moving to be done.

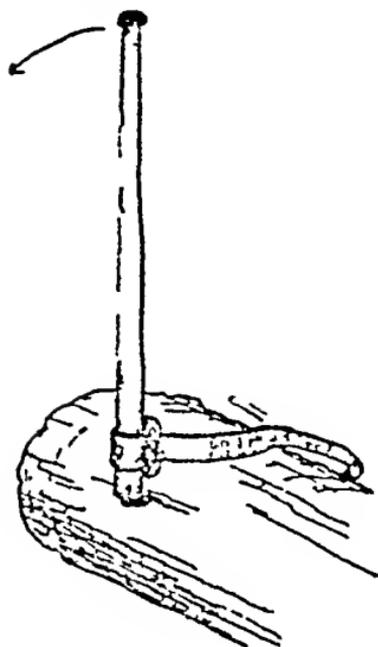

Fig 15

or slackened together the log may be moved, raised or lowered comparatively easily. If the strain upon the two ends is not

The Parbuckle

A parbuckle is used in order to move logs or other cylindrical objects on the ground, or to haul them up or lower them down an inclined plane. The rope is bent in two and the loop hitched round a tree stump, post or other firm anchorage. Both ends of the rope are then passed under the log, round behind, and over it, and are brought back in the direction of the anchorage (Fig 16). If the

ends of the rope are hauled taut

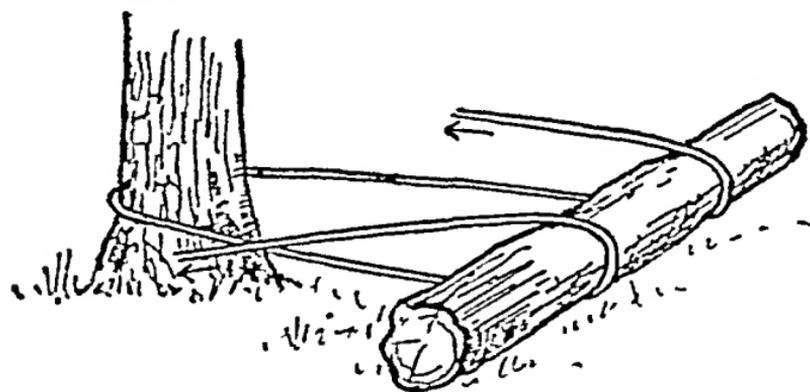

Fig 16

equal the direction of a log may be changed slightly, but if a short object—such as a cast—is being moved, it may readily slip out of the parbuckle.

MOVING HEAVY WEIGHTS

Blocks and Tackle.

The best method of moving heavy weights, however, is to make use of blocks and tackle. By this method not only can heavy weights be moved easily along the ground, but they can be lifted as well without any very great exertion. Since blocks and tackle and lifting weights are dealt with in Chapters X and XII of *Knotting*, it is not intended to repeat the greater part of the information given there. There are, however, certain other considerations into which we may go

To Reeve Blocks

The process of attaching a rope to blocks so as to turn them into "blocks and tackle" is called reeving. Two fellows stand back to back within arm's reach of one another. The blocks lie between their feet, hooks to the front and on their sides. The coil of rope should be to the right of the block having the most sheaves. The end of the rope is passed through the lowest sheaves of this block from right to left, then through the lowest sheave of the second block, also from right to left. The rope is then passed successively

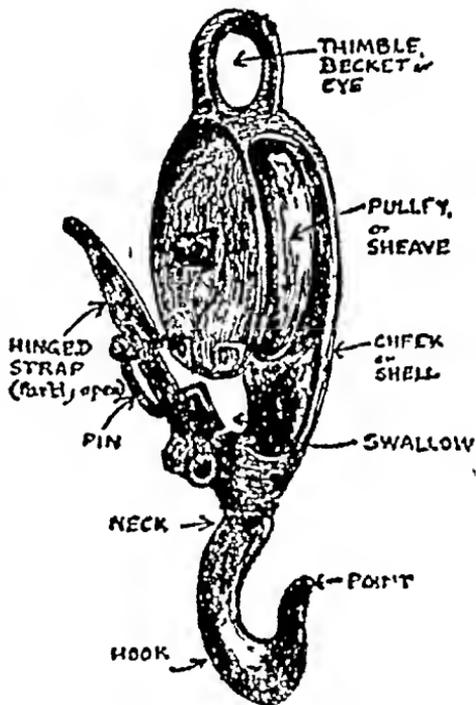

Fig 17.

through the other sheaves and is finally made fast to the eye or thimble of the block which has the least number of sheaves by means of two half hitches. The half hitches must be as close as possible and only a very short end left for seizing so that the blocks will not become "chock" (*i.e.* close up on each other) too soon. If a permanent tackle is desired, the rope may be attached to the thimble with an eye-splice.

When reeving threefold rope-stropped blocks, it is better to reeve so that the running end of the fall comes off the centre sheave. Set both blocks on their sides, pass the end of the rope through the centre sheave of No. 2 block from left to right; then through the upper sheave of No. 1 block from right to left; next through the upper sheave of No. 2 block from right

to left, carry it on through the lower sheave of No 1 block from *left to right*, up through the lower sheave of No 2 block from *left to right*, and finish off through the centre sheave of No 1 block from *right to left*. If the blocks are rove in this way it will do a lot to prevent twisting when the tackle is being worked.

Preventing Twist

When working with blocks and tackle it is important to see that the falls do not twist, or the running end press against the shell of the block. One complete twist in the fall will increase the power required by some 40 per cent. To prevent twisting a short picket can be placed between the returns of the fall close up to the block, and held in position by two light lines at its ends. With a light tackle it will probably be sufficient to lash the handle of a maul to the block, in which case the lashing should be passed round the head and back up the handle to prevent the maul working out.

Prices of Blocks

Blocks are a somewhat expensive item of equipment, unless frequent use is made of them. It is worth while, however, for Scouters to consider the possibility of suggesting to Local Associations the help that they could give by acquiring two or three sets of blocks for use by the Scout Groups in the Association.

Galvanised iron blocks cost (1931) roughly as follows

4-inch blocks to take 2-inch rope Single, 7s 6d ,

Double, 10s , Snatch, 12s

6-inch blocks to take 3-inch rope Single, 11s 3d ,

Double, 15s , Snatch, 18s

7-inch blocks to take 3½-inch rope Single, 13s 6d ,

Double, 19s 6d , Snatch, 21s

It is also possible to pick up blocks second-hand from time to time, especially in marine stores, where wooded blocks are frequently to be found. Wooden blocks are mostly made of elm, and though bulkier, weigh less than iron blocks.

Straining a Rope

In order to construct ropeways (see Chap VII), and for other purposes it is frequently necessary to secure a strain on the hawser or rope. In the case of ropeways this is best done by using blocks and tackle, one block being attached to the anchorage and the other to the hawser, as will be explained later.

A rough and ready method of getting tension on a hawser is by means of the Spanish windlass. This is a simple method

of shifting a load, such as hauling a car out of boggy ground, in the absence of ordinary appliances, and the principle is the same as a windlass

Spanish Windlass

One end of a rope is made fast to the load, and the other to a fixed hold, such as a tree or other suitable anchorage. A short stout spar is then held by one fellow vertically against the centre of the rope, while a second fellow takes a smaller spar, and inserting it in a bight on the rope, as shown (Fig 18), walks round the upright spar, upon which both standing and running parts of the rope are wound as the upright spar approaches the fixed anchorage.

The second, or hand-spar, must be kept above the turns of the rope. The amount of rope which can be wound up is limited, and it is advisable to take up the slack and make a fresh start at intervals, if the distance the load has to be moved is considerable.

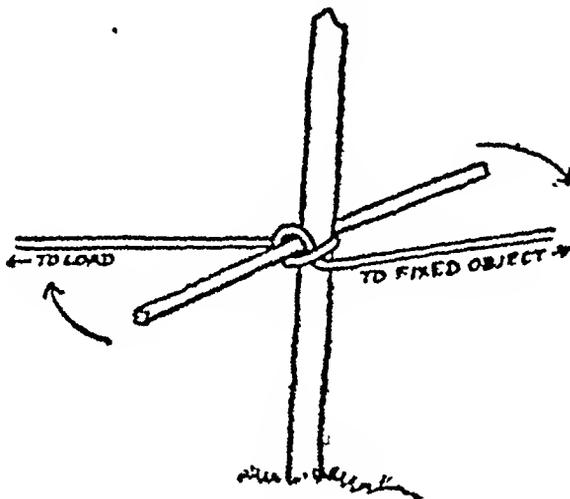

Fig 18

When a Spanish windlass is used for tightening up the hawsers of a ropeway, it is only a temporary expedient and should not be used on ropes that are to take a great weight, as it weakens the rope considerably. In this case it is possible to drive the first spar into the ground, and to lash the second spar to the rope to keep it in position when sufficient strain has been obtained.

This appliance is best reserved for Rover Scouts, as it must be used with great care. The principle employed is the same as in the Roman *ballista*, and the tension is quite sufficient to break a leg if the second spar, or windlass, is suddenly released. Make positive that no one except the two strong fellows engaged on the job are anywhere near the windlass, that it is lashed very securely when under strain, and that every precaution is taken when the windlass is unlashed in order to lessen the strain.

Rope Tackle

A very simple method of straining a rope which is not going to carry much of a weight is to use a rope tackle. Attach one end of the rope to a fixed hold, then make a bight in the rope and throw a half hitch over it, as if starting to make a sheep-shank. It is best to seize the short end of the bight to the standing part of the rope. Pass the free end of the rope round the anchorage and through the long end of the loop thus formed (Fig 19). This is the finished tackle, which should not, however, be set up too frequently in the same place in the rope as the rope is apt to be chafed badly at the bight. It is intended for emergency use only, but is very frequently employed to secure hay on a wagon, and is very useful for securing a load of wood on a trek-cart. In this case the first end of the rope is attached to the axle, the rope is thrown over the load, the tackle is set up a couple of feet above the axle on the other side, the free end is passed round the axle on the far side, back through the bight, and is made fast to the axle again by a slippery half hitch.



Fig 19

Relieving a Strain

Where a heavy strain is being taken on a rope and it becomes necessary temporarily to relieve the strain from the anchorage, a rolling hitch or stopper hitch is useful. The necessity may arise because the anchorage works loose, or needs to be moved, or because a weak place has been discovered in the rope under strain. The hitch can be placed in position whilst the strain, or pull, is being taken, and held in place. When it is required to transfer the strain, the hitch is tightened up and the strain taken by the stopper (Fig 20).

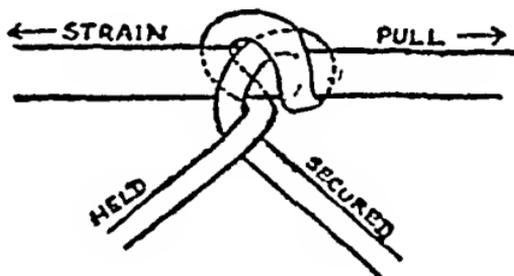

Fig 20

Pulling on a Rope

When possible, the persons pulling on a rope should be equally spaced on alternate sides of the rope, and should pull

with arms straight, using the weight of their bodies, and not with arms bent. By using some executive word of command, such as "one, two, three—PULL," all will throw their weight back at the same time and the maximum pull will be effected. Those on the rope should keep their feet together, square with the rope, and should all face the direction of the strain. In "walking away," when it is desired to keep the strain constant and the weight on the move, everyone faces away from the strain, stretching the arms to the full extent, and stamp the feet in time with each other.

Using the Round Turn

One, two or three round turns (Fig 21) around a smooth object, such as a tree, spar, or even a bundle of Scout staffs well secured, will enable a heavy strain to be eased or a heavy weight to be lowered with perfect safety. The turns are taken on top of the standing part, and, where possible, are eased from



Fig 21

the same direction as the strain. One turn is generally sufficient, and only when a very heavy strain or weight is involved are more turns necessary.

In raising a weight or taking a strain by short pulls the round turn is of great use. Before commencing to pull, the free end of the rope should be taken round a smooth object in a complete round turn. One person then takes the end in hand, and takes in the slack as the pulls are made. It is essential to be certain that the object selected round which to put the round turn is safe before the weight or strain is thrown on it. It is quite wrong to attempt to take the weight of a heavy object or strain by simply "hanging on," and such a course is bound to place too much of a strain on Scouts.

When lowering a person over a cliff or from a window, it is essential that something in the nature of a smooth object should be placed where the rope is likely to chafe. Over a cliff a Scout staff, well anchored, or at a push some turves or even a coat should be placed where the rope passes over the edge. Out of a window a pillow, mat, or rolled sheet or blanket will do. If the rope is taken around a post or other object with a round

turn it can be paid out gradually and the person lowered carefully and evenly

CHAPTER V

ANCHORAGES AND SHEER-LEGS

“ Very often it may happen that lives depend on a knot being properly tied ” (*Scouting for Boys*)

It is quite obvious that when any strain has to be taken on a rope some kind of a fixed hold is necessary in order to get a purchase. Such a hold is known as a holdfast or an anchorage. If a natural anchorage, such as a tree, can be obtained it saves a good deal of trouble. All that need be done then is to pass a strop round it and to anchor the hook of the block and tackle through both loops of the strop, or, if a Spanish windlass or other expedient is being used, to tie the end of the rope round the tree with a timber hitch. When anchoring a rope in order to take off from a holdfast of any size it is always best to use a timber hitch which can be freed, once the strain is removed, with great ease. A draw hitch, or highwayman's hitch, is sometimes used if the attachment is merely temporary, and no very great strain is employed.

Trees do not, however, always prove convenient to our purpose, and more often than not, it is necessary to set up an anchorage for ourselves.

The 3-2-1 holdfast

The 3-2-1 is the handiest and most popular form of temporary anchorage. The pickets composing it should be from 4 to 5

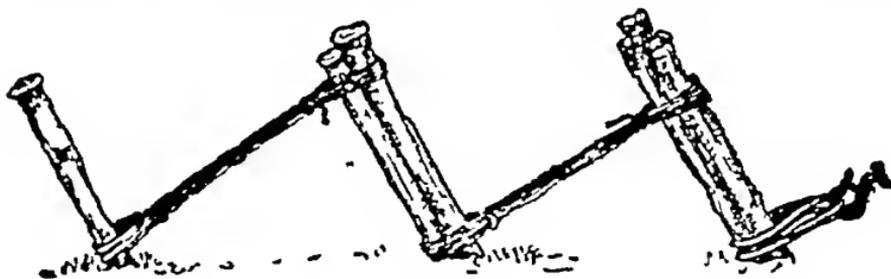

Fig 22

feet long and at least 3 inches in diameter, since not only have they to hold fast when driven into the ground, but to be strong enough in themselves to take a heavy strain without breaking

Great care should, therefore, be taken in the selection of the pickets in order to make the anchorage safe

When driven some 3 feet into the ground a picket will safely take a strain of 7 cwts. A 2-1 holdfast will take about a ton, and a 3-2-1 holdfast 2 tons. The pickets should be driven in as illustrated in Fig. 22 at right angles to the line of the strain and should be lashed together at right angles to themselves, the lashing extending from the top of the front picket to the bottom of the next. These lashings must be secured and the anchorage firmed up before any strain is put upon it. As soon as the strain is applied someone should be stationed to watch the anchorage and see that it does not draw or give to the strain. It is important to have a sentry always stationed on an anchorage while the strain is being worked, and the apparatus set up used.

Log and Picket Holdfast

For greater strains of a more permanent nature a buried log, known as a deadman anchorage, is used, but a log and picket

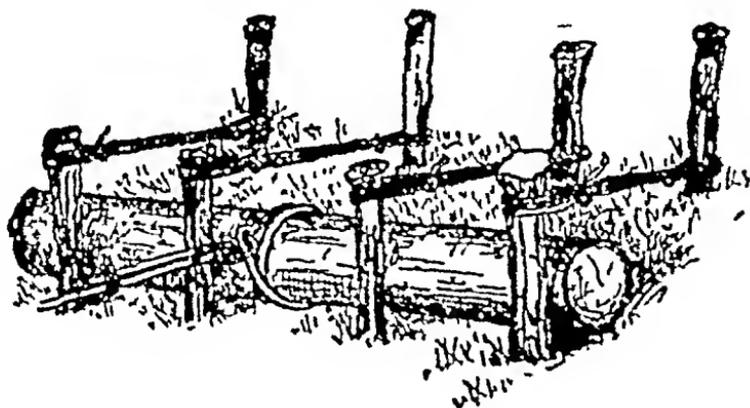

Fig 23

holdfast make a very good substitute for a "dead-man," and is more quickly and easily made (Fig 23). A log and picket anchorage will safely take a strain of 12 cwt for every pair of pickets. Make sure first of all that the log is placed at right angles to the direction of the strain, have the same number of pickets on each side of the cable that the anchorage is to hold, and see that the log bears evenly on all the pickets in front of it. A small trench should be cut under the log in order to pass the cable under it, since if the log is raised off the ground by the cable there will be a much greater strain on the pickets.

In all anchorages care should be taken to see that the angle

between the hawser and the ground is not more than 25° . It is a common mistake, when a hawser is being brought over sheer-logs before being anchored, to place the holdfast too close to the sheer-legs, the distance apart should be twice the height of the sheers

Sheer-Legs

Sheers, or sheer-legs, enter into the construction of ropeways (Chap VII) when height above ground cannot be secured by more natural or permanent means, they are also

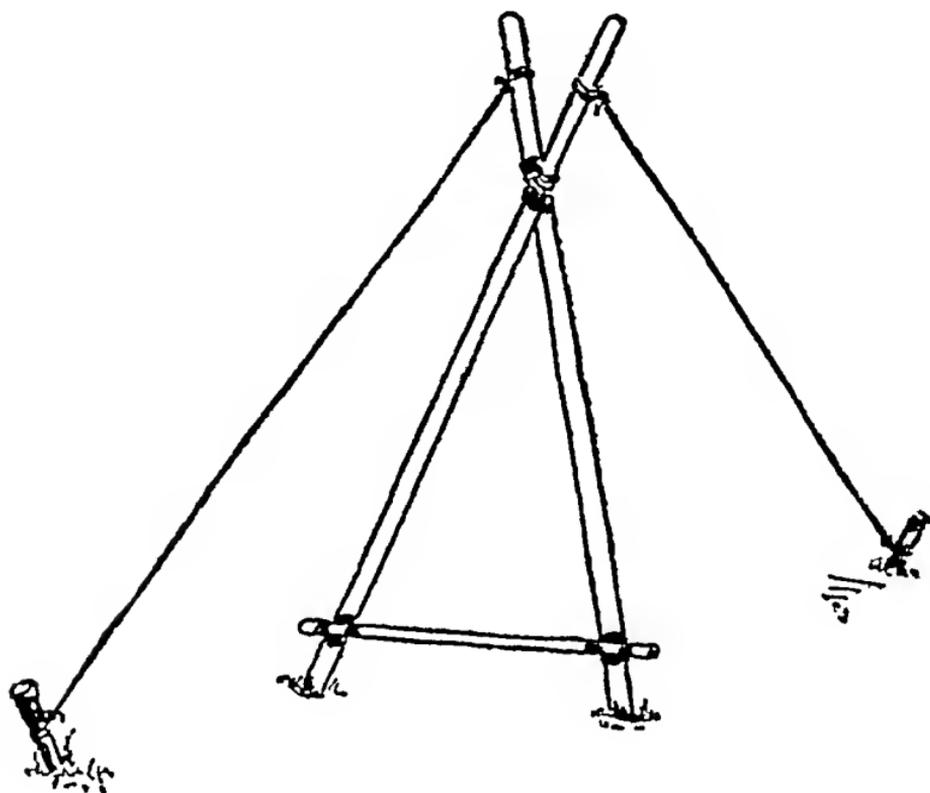

Fig 24

used for lifting heavy weights, but can only move a weight in a vertical plane between the sheer-legs and for a distance about equal to one-fifth of the height

It depends somewhat on the purpose for which the sheers are to be used, exactly where the legs are lashed together. If the sheers are to lift weights, then the sheer-lashing (p 21), will be placed close to the top of the legs, ending some six inches from the top, but for different types of ropeways the position of the lashing will be much lower. Whatever this

position is, the legs of the sheers should not be spread wider apart than one-third the height of the lashing from the butts. In order to prevent the sheers from slipping when strain is applied, it is essential that small holes should be dug in the ground into which the feet are placed. It will be thus seen that a certain amount of care and measurement is necessary before the sheer-legs are constructed and set up.

Sheers require only two guys—fore and aft—which should be fastened to the legs above the fork by a clove hitch and a half hitch round the standing part. The back, or aft, guy should be fixed to the fore spar, and *vice versa*, so that their action may tend to draw the legs closer together and not strain the lashing.

As soon as the sheers are erected a light spar should be lashed to the legs close to the ground, so as to prevent them from straining apart (Fig 24).

If the sheers are to be used for lifting weights, the upper block of the tackle is suspended from a strop, or sling, passed over the fork. If the sheers are to be used in connection with an aerial runway (see p 48), the hawser can be run through a block suspended in the same way, but a certain amount of height is lost in the process. Because of this the hawser is more frequently taken over the top of the fork, but, if this is the case, a "saddle" or pad of sacking should be placed in the fork in order to prevent the lashing from being chafed.

In lifting weights, sheers should never be heeled over more than one-third of their height. When used as supports for a ropeway they should only lean slightly from the vertical away from the anchorage of the hawser.

Safety Precautions

Great care has to be taken when working with sheer-legs, especially when lifting heavy weights, to see that dangers are minimised to the fullest extent. The importance of digging in the feet has been mentioned, the safety margin of lean has been alluded to, but care should also be taken to see that the anchorage of the guys is firm, and that any orders that may be given in order to tighten one guy and loosen another are thoroughly understood. Those on the job have to be previously instructed in the terms "fore" and "aft" and so on. The use of other terms of a like nature is also advisable. Scouts, and even Rover Scouts, are apt to get mixed about the points of the compass, while the use of the words "left" and "right" should always be avoided. Instead of them "port" and "starboard," or "near" and "off" are less liable to misinter-

pretation on the spur of the moment and the excitement of the job. Care should also be taken to see that none of these engaged on the job gets underneath the sheers, and that there are sufficient competent people on the job to cope with it if anything carries away.

Raising Sheers by means of a Lever Spar

It sometimes happens that it is necessary to erect a very heavy pair of sheer-legs, or even a flagstaff or derrick. Frequently this is done by means of a smaller derrick or sheers,

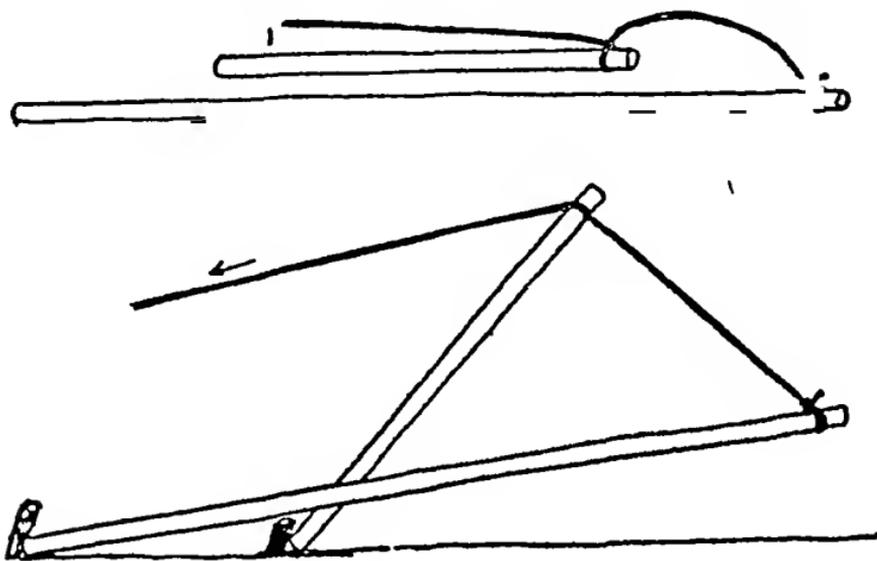

Fig 25

but for most of our purposes a lever spar will be found sufficient (Fig 25)

A spar one-half the length of the derrick should be laid beside it, centre to centre. In the case of sheers, the butt of the lever spar will be placed between the legs of the sheers. A sufficiently strong guy is then attached to the tip of the sheers and brought back to the tip of the lever spar, to which it is attached with a half hitch only, the length of the guy between the tip of the sheers and the tip of the spar being roughly two-thirds the length of the sheers. Foot-ropes should be attached to the butts of both sheers and spar, or pickets knocked into the ground, so as to prevent them sliding. Light guys should also be attached to the tips of both to prevent them from swaying. By hauling on the main guy the lever spar will be raised and will lever the sheers into position. The half hitch on the lever spar will hold if the strain is applied.

RAFTS

steadily throughout, then when the spar has served its purpose, it will come away easily when the strain is taken off.

This will be found quite an interesting and simple exercise in itself, and the principle of it can easily be demonstrated with a light spar and a Scout staff

Levering up Tent-pegs and Pickets

More frequently than not very great difficulty is experienced in lifting pegs and pickets from the ground after they have been driven in hard. The thought of this difficulty sometimes deters people from knocking in pickets as far as they should, with the result that anchorages and guys are left insecure. Once it is realised that this difficulty can be overcome easily, then there will be no hesitation in hammering pickets in hard. It is quite easy to remove a tent-peg by placing another peg,

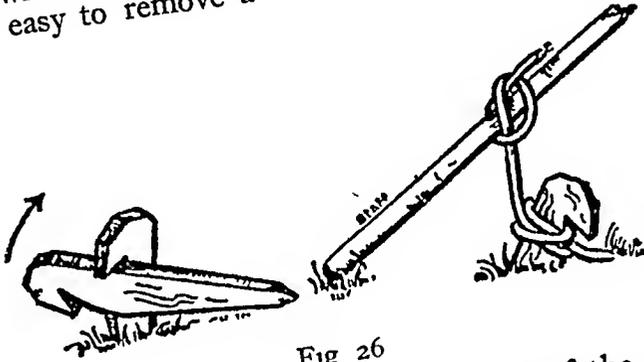

Fig 26

or short length of stick, underneath the tip of the peg in the ground, and levering it upwards as indicated in Fig 26. An alternative method which is used especially for pickets is to use a staff as a lever. A lashing is attached to the picket by a rolling or clove hitch, and the staff slipped through a marline-spike hitch so as to lever up the picket. Care must be taken not to have the line too long.

CHAPTER VI

RAFTS

“Rafts, too, can be used” (*Scouting for Boys*)

WHERE any kind of still or smooth water is available, or slowly moving streams, the building of rafts is great fun. The beauty of raft building is that all sorts of material, old and new, can be used, and that it affords scope for the exercise of a considerable

amount of resource and ingenuity. When experiments are being made, care has to be exercised—unless the water is really shallow—that only experienced swimmers try out the makeshift rafts that may result. The joy of launching some kind of a contrivance that one has helped to build one's self and finding that it actually floats and even supports a Scout—for a time at any rate—has to be felt to be believed. We all like messing about with water—men as well as boys—and given warm weather no harm can come from it provided normal common-sense precautions are observed to safeguard against chills and against accidents. Where water is deep, however, the Scouter *must* observe all the rules against drowning fatalities.

When the various means for crossing streams, etc., are considered, it becomes obvious that it is usually best to work from both banks, if not absolutely essential. Frequently the first thing to do is to get some Scouts over to the opposite side. If it is a pond, that is easy, although a little imagination can always turn a pond into a river the length of the Amazon! If the water is shallow, and the bottom firm, it is easy to wade across, but again a little imagination can easily turn it into a river as deep and dangerous as the Hooghly. If the current is slow, a swimmer can get across to the other side easily. Here is a lever to hand, if one be needed, to encourage the art of swimming. But, if necessary, imagination can easily conjure up crocodiles, and, in any case, the swimmer will usually require his clothes on the other side, and so the making of a raft becomes necessary.

A small pile of brushwood, lashed together, will provide a raft sufficiently buoyant to carry one's clothes, but something more than that is required in order to carry one's person.

The Coracle

Our ancestors used to ferry themselves over water in a coracle, and we can to-day imitate their methods just for the fun of the thing. These coracles were at first very primitive affairs, nothing but a circle of brushwood wrapped in a hide. We can imitate this with brushwood and a small tarpaulin. First the brushwood is built into what is technically known as a circular fascine. Drive 2-foot pickets into the ground in two circles, one about 4 feet in diameter and the other 5 feet. Pile brushwood between the two circles of pickets, thus making a wreath or tyre. The brushwood should be "stopped down"—that is tied round—every foot with yarn twisted round it several times (Fig 27). The fascine is then lifted and placed on the tarpaulin, other lengths of brushwood being laid inside the circle of the

RAFTS

fascine in order to form a floor. The ends and sides of the tarpaulin are now folded over and lashed securely across the top of the fascine. Great care should be taken in this process so as to ensure that water will not enter between the fold.

The coracle can then be launched, and a volunteer called for to navigate it, which is no easy matter since the tendency for it

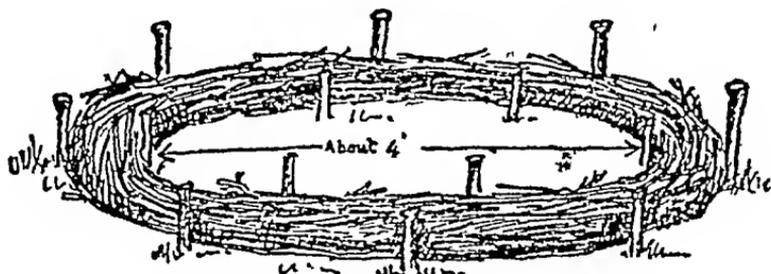

Fig 27

is to go round rather than to progress in a straight line. If the fascine is built oval-shaped, the craft will be more easily steered.

The Crate Raft

The Ancient Britons were apparently very fond of wattlework, and their coracles became more ambitious in construction and design. A wattle framework was built up basket fashion so as to give depth, and this was covered with hide as before. This contrivance had a greater displacement in water, and more draught, and frequently had some kind of a seat lashed across it. A large china crate sawn in half will be found to provide a most excellent framework, a tarpaulin again replacing the hide.

After a time these primitive people began to make elongated boats in the same way, and even to-day the Eskimos fashion boats of driftwood, laced together with thongs, without a single nail, and covered with skins. And so we get on to the fashioning of canoes, into the making of which it is not possible to go now.

The point, however, chiefly at issue is that we can build a craft that will ferry us over a smooth stream or pond with what at first sight may seem to be the most unpromising of materials. Even if a local shop cannot provide you with some kind of crate to use as a framework, you can purchase one anywhere at very little cost. A worn-out tarpaulin can also easily be procured and will provide a sufficiency of fun. If it leaks a little that will not matter, provided you are prepared to bale and to risk a wetting. The chief point to remember is that your feet and body should rest on the framework, or some solid object lashed across it, and not on the tarpaulin itself.

Paddles can be made out of pieces of board, or ingenuity can be exercised on such things as biscuit-tin lids. Frying-pans have also been used for paddles, while the hand itself is not such a bad substitute!

Log Rafts

"Pithecanthropus, if he ever went boating, did so on any floating log, and discovered to his disgust that it needed pointing, if it was to be paddled along, and also that some sort of arrangement was necessary to prevent it rolling over in the water, and giving him an involuntary bath. The beginning came in some such way. One development was the dug-out, and certain prehistoric men, with fire and flint, shaped and hollowed their logs in this way.

"The Tasmanians had one notable possession in their raft. This was not hollow like a boat, but made of cigar-shaped rolls of very light bark like cork. One large central roll had two smaller ones lashed to it with grass ropes to prevent rolling." (From *Everyday Life in the Old Stone Age*)

This extract is of interest, not only because it demonstrates development, but because it teaches us how to construct a simple log raft for ourselves, and mentions the value of "grass" rope.

To form a makeshift log raft an uneven number of logs should be lashed together—figure-of-eight lashing is best—and the smaller logs should be placed on the outside so as to make the raft more navigable. It is always advisable to lash a spar or two at right angles to the logs, so as to keep them in position and make the raft rigid.

"Grass" rope floats and is springy, and is, therefore, especially useful for towing and life lines.

Before going on to mention rafts built of more modern materials, it will not come amiss to emphasise the value of using historical and archæological illustrations when we are talking of, and demonstrating, pioneering. Romance must enter into our Scouting, if it is really to live in the minds of our Scouts, and of our Rover Scouts too—here is excellent material for a Quest. It will add to the fun, and to the value too, if history is re-enacted, and the part of the Ancient Briton does not need much dressing up. We can easily go still further back than the backwoodsman, explorer and frontiersman for our inspiration.

The Sausage Raft

The tarpaulin raft is still used as a bridging expedient in the Army in order to pass men and artillery across water at the

earliest possible moment before work of a more deliberate nature is completed. Such rafts are usually built 18 feet by 15 feet, and will carry a load of 24 cwt. The Scout counterpart is the sausage raft, which appeals to us by reason of its name alone. It has proved a very successful raft under the most trying conditions (there is many a tale hidden behind that expression!), and if well made and used with care will carry two or three boys, or even two men.

The materials required are six groundsheets in good condition (if they are not thoroughly sound the water will get in), a quantity of straw or brushwood, six Scout staffs and several yards of sisal or binder-twine. A 6-lb ball of sisal works out at about 80 yards for 1s. The groundsheets are laid on the ground, waterproof side down, and a good bundle of straw placed on each, straw is better than brushwood since the latter is more difficult to deal with and may damage the groundsheets. The straw is then wrapped up in the groundsheet, which is lashed round it so as to make a sausage-shaped parcel about 4 feet long and a foot thick. As much straw should be stuffed in as possible in order to make a good, firm, symmetrical sausage, the better the sausages, the more buoyant will be the raft, which is possibly true of sausages and Scouts, too. The ends of the sheet should be turned up over the ends of the parcel so that water will not get in.

The six sausages should, as far as possible, all be the same size and shape, despite the fact that it is best to detail a separate pair of Scouts to each in order to get the job done, and have as many occupied as possible. When finished, they should be laid side by side, lashing side up.

Meanwhile a trestle of staffs should have been built by another Patrol. This trestle should be rectangular, all the lashings being square, with the exception of a diagonal lashing where the two diagonal staffs cross. As will be explained in Chapter IX, one end of these diagonals is placed on the opposite side of the framework from the other three.

The trestle is then laid on top of the sausages and is made fast to them in this way (Fig 28). The end of a piece of sisal is made fast to one of the corners of the trestle by means of a round turn and two half hitches. The sisal is then carried round underneath the first sausage, up over the staff, down round the next sausage, and so on until all are secured, the other end being made fast to the opposite corner by a round turn and two half hitches. It is most important that each sausage should be pushed up well against the one before it, and that the sisal should be kept as tight as possible. The

other ends of the sausages should be secured to the other side of the trestle in the same way. The middles of the sausages should also be secured by passing the sisal under the first three sausages, making it fast to the cross of the diagonals and then passing it under the second three.

The raft is now complete, but should be launched very carefully so that water is not splashed over the sausages, since it will obviously penetrate through the joins in the groundsheets. Care should be also taken that no weight is placed on any part of the sausages, but on the trestle only. It is better, and much more comfortable, if a piece of board is lashed across the

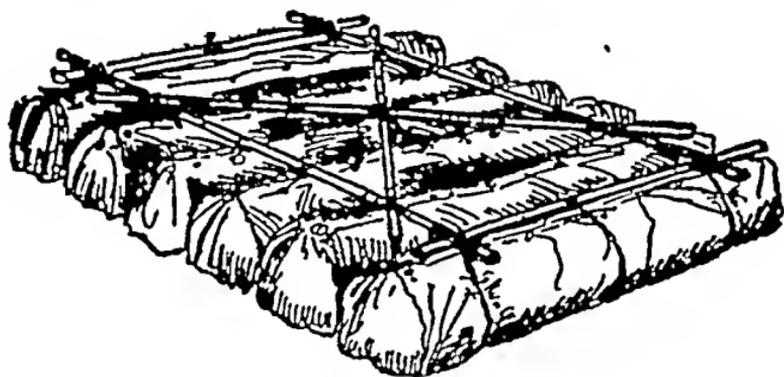

Fig 28

trestle, and this is essential if the raft is to carry more than one person.

The Petrol-tin Raft

In a similar kind of way rafts can be constructed by using petrol tins, oil drums and other improvised floats. Whatever the materials used, the principles of construction are the same. The simple form now described will support a Scout, or even a moderate-sized Rover Scout or Scouter. Larger rafts can be constructed in the same way in order to carry greater weights.

A petrol-tin raft is very strong, and remains in a serviceable condition for practically an unlimited time. It will usually be found, too, that if it is not possible to purchase tins or drums, they can easily be borrowed from a garage or elsewhere, if required only for a time. The one essential precaution is to see that the caps are screwed on tightly.

Six staffs, a fair quantity of fair cord, and twelve petrol tins are all the materials required. The staffs are lashed into a frame as illustrated in Fig 29, the distance apart of the staffs in each side pair being determined by measuring with one of the tins, the outer edge of these staffs should come up against the bead-

ing at the top and bottom of the tin Square lashings are used at each of the eight points where lashings are required

Then place six tins side by side, with the narrow side on the ground, and the caps towards the upper side and pointing outwards

The same is done with the other six tins The trestle is then placed on the two lines of tins and lashed tightly to them as shown in Fig 30 The two rows of tins should be as far apart as the lengths of the staffs permit, the

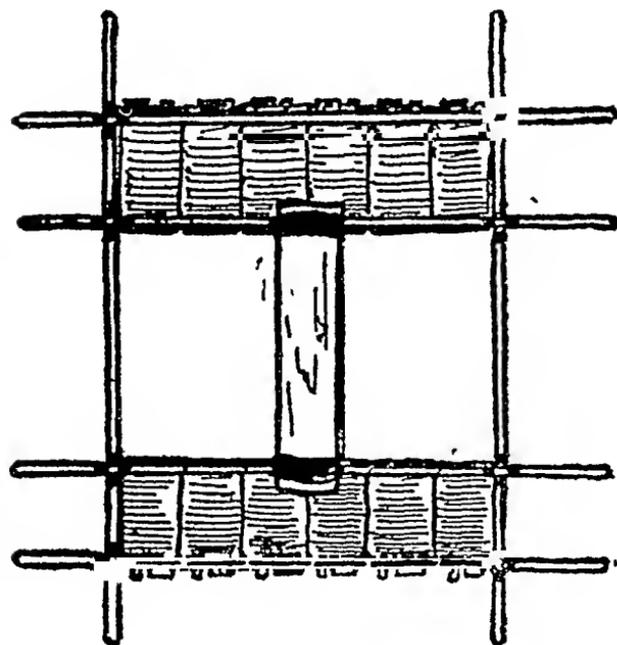

Fig 29

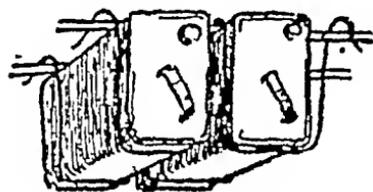

Fig 30

further apart they are the more stable will the raft be in the water The tins in each row should be lashed close alongside each other without any gaps between A piece of board is then lashed across between the two rows of tins, on which the adventurer sits, and the craft is ready to be launched

The Catamaran Raft

A catamaran raft is simply a light framework lashed together and placed on a barrel as shown in Fig 31 The framework

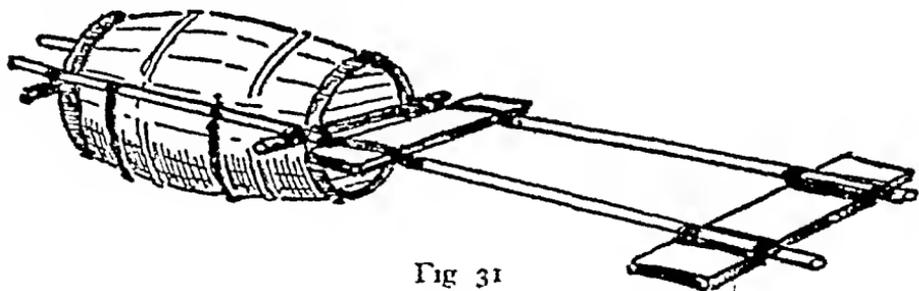

Fig 31

must rest on the rounded part of the barrel so as to prevent the buoyancy of the barrel pushing itself through Two

lashings are fastened to the side pieces and passed round underneath the barrel so as to secure the framework to it. The side pieces—hop poles will do excellently for these—are carried well back, tapering outwards, and another spar or plank lashed across them near the ends. A flat plank is better than a round spar as it gives more purchase on the water and is better able to prevent the barrel from rolling. One or more Scouts, according to the size of the barrel, can sit across it and paddle or pole themselves along. To find the safe weight a barrel will carry, multiply the capacity of the barrel in gallons by nine. This gives the safe load in pounds. Thus an 18-gallon barrel will carry 162 lbs.

Towing Lines

In order to work rafts more quickly it is usually best to attach towing lines. When the raft is launched a line should be attached to the back of the frame with a timber hitch, or a round turn and two half hitches. Another line should also be attached to the fore part of the frame and coiled on the raft. The first line is paid out as the raft is navigated across the stream, the occupant jumps out on the far bank, taking the second line with him, and subsequently the raft can be ferried forwards and backwards by pulling on these two lines. The pull should be steady and not too strong, as otherwise there is a danger of sinking the fore part of the raft with too quick a pull. For the same reason weights should be distributed so as to rest more on the back half of the raft than the front half.

If light pulleys are placed on convenient trees on the banks, or on spars rigged for the purpose, a continuous towing line can be used by the occupant of the raft himself, the line passing from the back of the raft over the pulley on the near bank, across the stream and over the pulley on the far bank, and back to the front of the raft again.

The Lob Line

If the far bank is wooded, or covered with projections round which a line will catch, it is possible to use a lob line in order to assist the first occupant of the raft over. A forked stick about a foot long is weighted by attaching a stone to one end. This is called a lob stick, and with a little practice can be thrown some 150 feet. A light line is securely attached to the other end of the stick, and is carried across with it. An ordinary tent mallet makes quite a good lob stick. If the lob line carries over bushes or other obstacles, a light pull on it may cause it to catch, and the fellow on the raft can then haul himself over.

hand over hand. In order to keep the line clear when the lob stick is thrown it should be laid out beside the thrower in a zig-zag pattern. A lob line can also be used to measure the width of a stream with accuracy.

Sails

In addition to paddling and towing, rafts can also be moved by means of the wind, especially if launched on a pond or small lake. Here is where ingenuity can come into its own in the construction of both mast and sail, and there is really no need to say more about it than that the mast will have to be properly guyed in order to prevent it being carried overboard. It is wonderful what a good sail can be made out of a blanket, and what an amount of amusement can be got out of sailing a raft in quiet waters.

CHAPTER VII

ROPEWAYS

“There are many ways of making bridges” (*Scouting for Boys*)

THE term ropeways is being used to include all those methods of crossing a stream or crevasse where the principal materials used in the construction of the apparatus are ropes.

The most elementary form of rope bridge is not a bridge at all but a swing. This is the giant's stride which is used sometimes to cross over very narrow gaps of not more than 20 feet. A giant's stride can only be erected where there is a convenient branch over which a rope or lariat can be thrown. The branch must be so placed that a person can jump from the near side of the gap, holding the rope swing, and land on the far side by letting go of the rope when it has reached its maximum swing. The rope should be long enough to cross the branch and return to the near side, the two parts should then be knotted together, and the rope grasped as far up as possible. It will quickly be realised that withdrawal from the bank of the stream in order to take a running jump will entail lengthening the rope, and, possibly, a wetting. This is a very elementary form of pioneering, but it can raise a good deal of excitement when introduced into some kind of a Patrol obstacle expedition principle can also be used in climbing to swing from branch, or even from tree to tree.

The Aerial Runway

An overhead transporter is frequently used to carry men and materials considerable distances over streams and over valleys, or down hillsides. A small aerial runway can be constructed with very little material. In its simplest form all that is required is a length of good rope, a block that is large enough to run freely along the rope, another short piece of rope with which to make a chair, and some yards of sisal. If a woven lariat is used for the rope then a small single block, of wood or metal, can be bought quite cheaply. If there are two small trees conveniently situated, this simplest form of runway can then be constructed. If a stream runs between the trees so much the better, but this is not essential.

One end of the lariat is passed through the block, and is then made fast to one tree, by a round turn and two half hitches, in trees of small diameter this is probably preferable to a timber hitch. The rope is passed across to the other tree, hauled as tight as possible, and made fast. The middle of the length of sisal is fastened to the hook of the block, not the thimble, so as to haul it backwards and forwards. The other length of rope can be made into a chair knot or a double bow-line on a bight and made fast to the hook which should be "moused" by binding a few turns of sisal between its neck and point so as to close the gap and prevent the chair from falling off the hook if it gets upset. One loop of the chair is passed under the passenger's knees and the other loop under his arms.

Some similar contrivance can easily be rigged indoors from a pillar to a stout hook let into the wall.

A real runway which will carry heavier weights over a longer distance needs more rigging. For real working purposes a 3-inch hawser is necessary, and this will have to be strained taut preferably by blocks and tackle. It is best to imagine such a runway crossing a fair-sized stream.

One man crosses the river—mention of ways of doing this has been made in the last chapter—hauls over one end of the hawser and makes it fast to a convenient tree at a height of 6 or 7 feet above the bank by a timber hitch. Very seldom will a convenient tree be found on the near bank opposite the first, and so it will almost always be necessary to erect a pair of sheer-legs on the near bank so as to carry the hawser at the necessary height above the water. These sheer-legs are set up as described on page 36, all the necessary precautions being observed. The rope passes over the sheers, through a block or over a saddle. If no natural holdfast is available, a 3-2-1

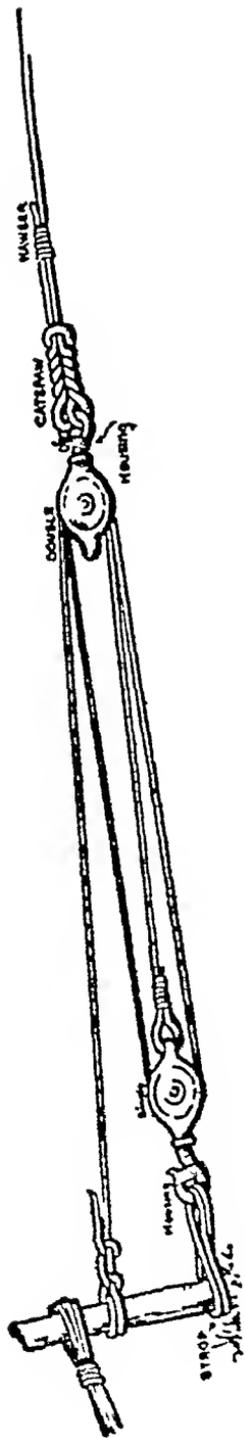

Fig 32.

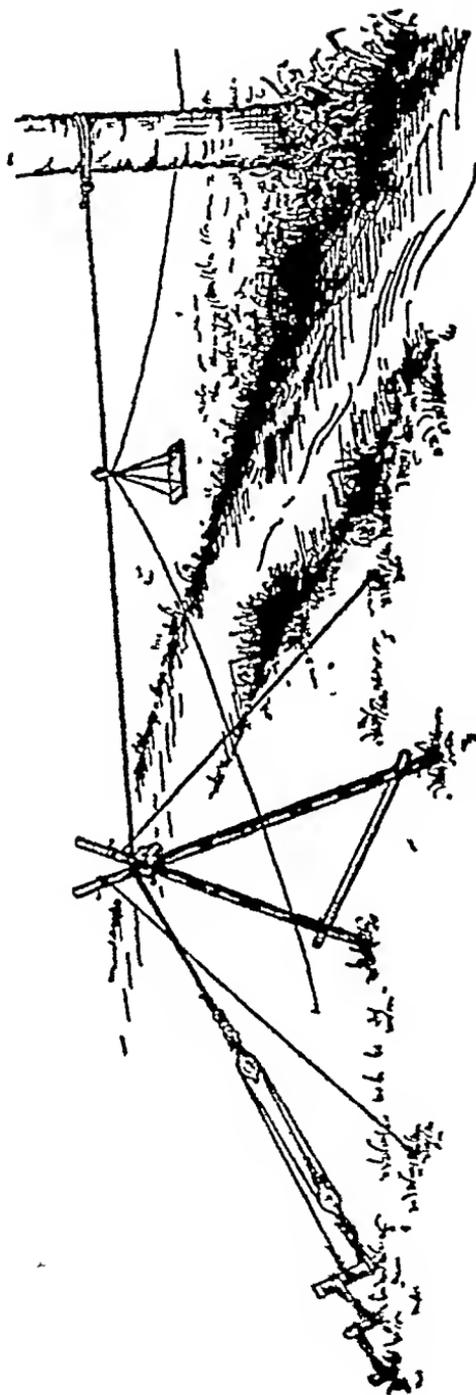

Fig 33

anchorage is driven into the ground in a *dead straight* line with the crotch of the sheer-legs and the take off from the tree on the far bank, and at a distance from the sheer-legs of over twice their height

Blocks and tackle are then attached to the anchorage by means of a strop and to the hawser by a catspaw or blackwall hitch. The pull from the tackle should be from the top block and away from the stream. The hawser is then tightened up by bearing on the tackle, the free end of which is made fast by a round turn and two half hitches round the foot of the front pickets of the anchorage (Fig 32). The runway is now ready for the bo'sun's chair (see p 26) which is attached to the hook of a snatch block placed on the hawser. If no snatch block is available then an ordinary block will have to be rove over the hawser before it is attached to the blocks and tackle. The hook should be moused, and lines attached as mentioned above. The chair can then be hauled backwards and forwards by means of an endless line or man-hauled from both banks (Fig 33).

The complete gear required for this apparatus is 1 3-inch hawser, 1 convenient tree, 2 spars 12 feet by 6 inches, 1 spar 5 feet by 4 inches, 1 light line twice as long as the hawser, 1 snatch block, 1 set double blocks and tackle complete, 2 guy ropes for sheer-legs, 8 pickets for anchorage and guy lines, 1 small plank and rope for bo'sun's chair, 5 good lashings, 1 strop, 1 piece of canvas for the "saddle," a few odd pieces of sisal, 1 spade and 1 maul.

If the blocks and tackle are not available then one of the other forms of straining the hawser can be utilised, but this is not very advisable for this type of runway.

In a job of this kind great care has to be taken to see that all lashings are firm, that the anchorages do hold fast, that the hawser is tightly strained, that the tackle is firmly secured, that the hooks are properly moused, and that no one puts his hand in front of the snatch block when the runway is in use. It should not be necessary to repeat the precautions to be observed in the erection of the sheer-legs.

The Monkey Bridge

"In India, in the Himalaya Mountains, the natives make bridges out of three ropes stretched across the river and connected together every few yards by V-shaped sticks, so that one rope forms the footpath and the other two make the handrail on each side. They are jumpy kind of bridges to walk across, but they take you over, and they are easily made" (*Scouting for Boys*) In the same yarn is an

illustration of a rope bridge. The normal monkey bridge has, however, sheer-legs set up on each bank instead of the form of trestle and anchorage shown there.

Two Patrols can be set to work on a monkey bridge at the same time, one to build the sheers and the other to connect the ropes together and finally to attach them to the sheer-legs. Sometimes convenient trees may be found to replace one, or still more rarely, both of the sheers, but generally speaking the following gear will be required

One 3-inch hawser, 2 lighter ropes of similar length, 4 spars about 9 feet by 6 inches, 12 pickets for anchorages if natural holdfasts are not available, 6 good lashings, ball of sisal or Scout staffs, 2 pieces of canvas as "saddles," spade and maul

Footings for the sheers some 4 feet apart and a few inches deep require to be dug on either bank. Spars should be lashed at a point about 4 feet from their tips, and not near the top

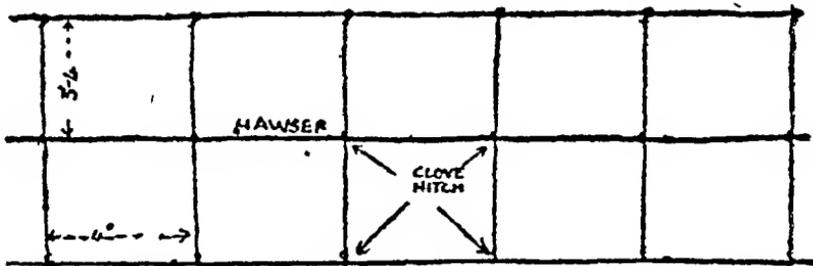

Fig 34

as in the case of sheers for the aerial runway, and erected in the footings. Anchorages are driven in at least 6 feet behind the cross frames or sheers.

The other Patrol meanwhile should lay out the hawser and two ropes on the ground, the ropes on each side of the hawser and from 3 to 4 feet from, but parallel to, it. At intervals of 4 feet the three ropes are connected together with stout sisal. This is best done by clove hitches round the outer ropes and a clove hitch round the middle hawser. Rough measurements will be required to find out the number of pieces of sisal to put on, and work should start from the centre of the ropes where they are tied 3 feet apart and work out gradually, widening to 4 feet apart (Fig 34). Careful measurement and knotting at this stage will save a considerable amount of trouble later on.

When the ropes, cross-frames and anchorages are all ready, the ropes are slung across the river, every endeavour being made to keep them dry in the process. To effect this the ropes should be wound together, and a line passed

far bank fastened to them. If a fair strain is maintained, the ends of the ropes can be hauled across to the far bank, without going through the water, although the sag may damp the middle slightly. The ropes should then be untwisted and the hawser laid across the canvas guarding the lashing—sheer rather than diagonal—where the spars cross. The outer ropes are made fast to the spars 4 feet above the cross by clove hitches (Fig. 35). All three ropes are then made fast to the anchorages.

The hawser, or roadway, is made fast by a round turn and two half hitches round the bottom of the first pickets. The rope handrails can either be made fast separately in the same

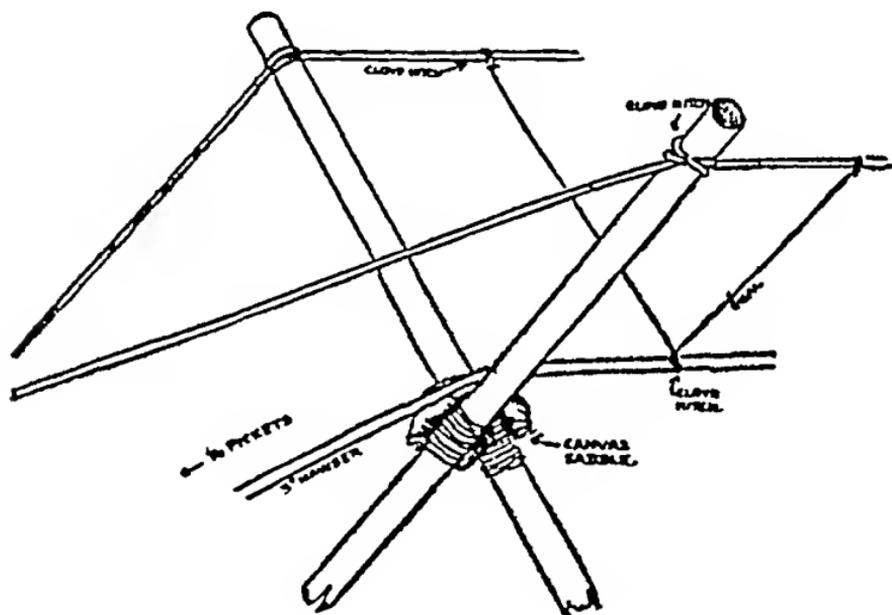

Fig 35

fashion, or their ends passed round the pickets and tied together. Tension can then be put on the hawser by means of a Spanish windlass or other device. Blocks and tackle can be used for this purpose but are not really necessary. When tension is applied to the footway, which will carry most of the weight, care should be taken to take up on the handrails in the same direction, as otherwise the connecting cords will go off at an angle to the vertical plane, which is apt to upset the balance of the whole bridge. The whole erection should be carefully tested by a responsible person before being opened to passenger traffic, special notice being taken of anchorages, safety of the straining device, lashings and knots. Two inexperienced Patrols should be able to erect a rope bridge of

this nature over a 24-foot crossing in well under the hour (Fig. 36)

Instead of using sisal to unite the three ropes together staffs can be used. They have the advantage of making the bridge

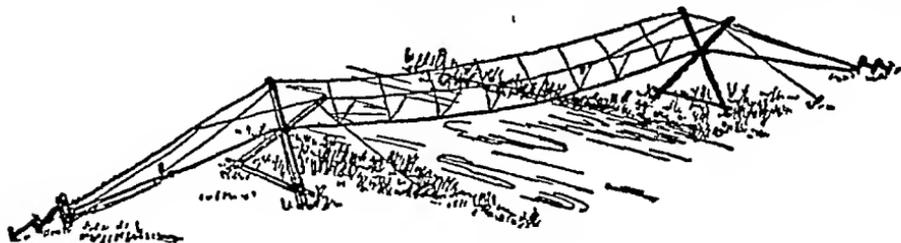

Fig 36

more rigid, but they are more difficult to handle. The staffs are laid on the ropes at right angles to them, each pair being about 6 inches apart, and 3 feet separating each pair along the ropes. The staffs are attached to the ropes by sisal, using square lashings. A variation of this staff method is suitable for Scout rallies and is mentioned on page 92.

Lariat and Staff Bridge

Another variation of the monkey bridge is generally known in Scout circles as the lariat and staff bridge, and sometimes as the "Luton Hoo" where it was introduced into the Scout world. Varieties of it, however, have been known in other parts of the globe for some time. This differs from the monkey bridge in that the whole of the weight is thrown on the hand-rail ropes, and the footway is made of Scout staffs.

For a span of some 20 feet the materials required are 5 Scout staffs, about 60 feet of 1½-inch or 2-inch rope, not necessarily all in one piece, several yards of sisal and 4 tent pegs. Materials in the shape of trees for anchorages, or, failing them, extra staffs and spars, will also be required.

Lariats, or spinning ropes, will do admirably for the ropes—hence the name. For longer spans more rope and staffs are all that is required, but every foot added to the length of the bridge lessens its security considerably.

The footway is constructed first of all. The staffs are laid out on the ground with the ends overlapping about a foot. Each joint is secured by one sheer lashing at the middle of the overlap. Sometimes the mistake is made of fastening each joint with two lashings in order to form one continuous rigid footway. This is contrary to the whole idea of the design, the single lashing allows the footway to be cambered, and prevents broken staffs.

PIONEERING

The handrail ropes are then laid out on the ground in two curves, one on each side of the footway, and are connected to it by sisal in the same way as in the monkey bridge. The distance apart of the handrails from the footway should rise gradually from 3 feet 6 inches in the centre to 4 feet 6 inches at the ends, the connecting cords being placed at each joint and in the middle of each staff only (Fig 37)

One end of the handrails can then be carried over to the far bank. When there are convenient trees the handrail ropes can be made fast to them, but it is hardly likely that four such trees will be found where required, so that some other means, such as sheers, must be found of securing one, if not both ends. A simple method is to construct an ordinary trestle of staffs (see p 62). The handrail ropes are attached to the transom close to the leg on each side and are then carried out and down to a tree or picket holdfast. The bottoms of the legs of the trestle should

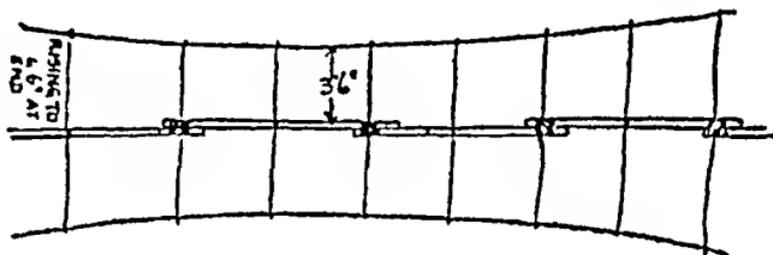

Fig 37

be placed in small holes in the ground and the trestle itself should be guyed to prevent its tipping sideways. It is important that the handrail ropes be strained as tight as possible, some kind of rope tackle will achieve this sufficiently well.

Finally, all that remains to be done is to peg down the end of the footway on each bank in order to lessen the sideways swing, which is always such a disturbing feature of any form of monkey bridge.

CHAPTER VIII

SIMPLE AND LIGHT BRIDGES

“The simplest way for bridging a narrow, deep stream is to fell a tree or two trees side by side, on the bank, so that they fall across the stream” (*Scouting for Boys*)

The larri and staff bridge forms a half-way house between ropeways and bridges which depend on wood and poles for

their strength, it falls on the ropeway side of the line because its weight is suspended from the handrail ropes.

There is room for a great deal of improvisation and experiment in the shape of bridges made of Scout staffs, logs, light poles and so on. As has already been mentioned, a good deal of preliminary practice in lashing, etc., can be achieved by using Scout staffs, and they can be even put to far more practical use in the open and in camp, as will be seen later. Other materials that may be found lying about, or easily purchased or borrowed, can also be utilised for pioneering jobs. Too often the cry is, "We cannot possibly procure these expensive materials," and no attempt is made to see what materials are available or can be procured. The builder's yard will yield a quantity of light spars, broken-down ladders and so on, that can be borrowed, when the owner is tactfully approached, or bought for a mere song.

Again, in various parts of England, for instance, use can be made of hop poles, which can be procured new at a cost of about 19s a hundred, less carriage, and even cheaper after they have been used for a time. Such poles, being mostly made of ash, will stand a good deal of strain. When purchased they should at once be debarked, and, if thought necessary, treated with creosote or oil as a preservative.

Scout Staffs.

Scout staffs have already entered into our calculations, but use can be made of them alone in erecting light bridges across ditches and so on in camp. Single Scout staffs are not very strong, but when lashed together in pairs they are capable of withstanding the weight of a normal Scout at any rate. The thick end of one should be placed against the thin end of the other, and the pair bound tightly together in three places, near the ends and in the centre. Three or four such pairs laid across a couple of staffs and lashed to them at a slight distance apart will soon bridge a narrow ditch that may otherwise be the cause of accidents.

Sheer-legs can also be made of two pairs in the usual way, with a single staff lashed to them as a ledger. This can be used for a miniature aerial runway or a succession of them to make a bridge, other pairs being used as a footway, and the handrail being separately suspended. Staffs can also be used as pickets in an emergency, but their respectability will suffer from such use.

One or two inter-Patrol Competitions in the uses of the Scout staff, in the building of trestles of various kinds with

staffs, will give a good deal of practice, even indoors, and encourage Scouts to make use of any ingenuity they possess

Using Logs

The earliest bridge-builders, when they wanted to cross a narrow stream or gully, merely selected a suitable tree that grew on the edge, and felled it across the gap. Later they became more fastidious, and smoothed off the top with their axes and even went the length of putting up a handrail by means of twisted creepers. Logs can still be used to throw a bridge across ditches and will have a great deal of permanency and so are, perhaps, the most suitable kind of bridges to erect over narrow gaps in a permanent camping ground.

There is also scope in this direction for the erection of narrow bridges on permanent rights of way by Rover Scouts. In such cases permission should invariably be obtained from the necessary local authorities before any service job of this kind is undertaken.

When logs are used for bridging ditches, two principle methods of construction can be utilised, besides many different methods arising out of these. If the logs are thick and solid, and of suitable wood, they can be split and the halves laid, split side up, alongside each other. For a footway two halved logs will be sufficient, for trek-carts four or more will be needed. If wedges and maul are not available, or if the logs are difficult to split straight, then the top sides can be smoothed off by scoring and hewing with an axe. This, however, is most certainly not a job which should be given to anyone who is not practised with an axe and has not sufficient strength to control it when swung vertically along the top of a log. In fact all this kind of log-work is really the reserve of Rover Scouts.

The other principle method is used with logs of narrower girth, or with poles. These are laid side by side across the ditch, the ends as in the former method being let into the bank so that the tops are more or less flush with the ground. The poles are then lashed together with wire, brushwood or heather laid on top, and earth stamped on top of all. Such bridges will be greatly strengthened if cross-bearers are lashed across at right angles to the poles, either underneath to give strength, or on top as road bearers.

It must be understood that such methods can only be used where the ditch, or stream, can be crossed by throwing across a single span, for broader places trestles will have to be utilised as described in Chapter IX.

The Ladder Bridge.

An easy way of making a one-span bridge of a temporary character is to make use of a ladder. The ladder is not laid flat on the ground and pushed over the gap, as it would be bound to sag in this position, and be liable to break, but is used as a kind of girder to support the bridge. Narrow holes are cut in the banks as slots into which the ends of the ladder are placed, the ladder being placed in the slots on its side. Brackets are lashed along the ladder at intervals so as to form trestles on which the roadway rests. Fig 38 shows the way in which this is done. Staffs cut in half provide very suitable material for this purpose. After the ladder has been placed in position and planks laid on the brackets, a few light stakes

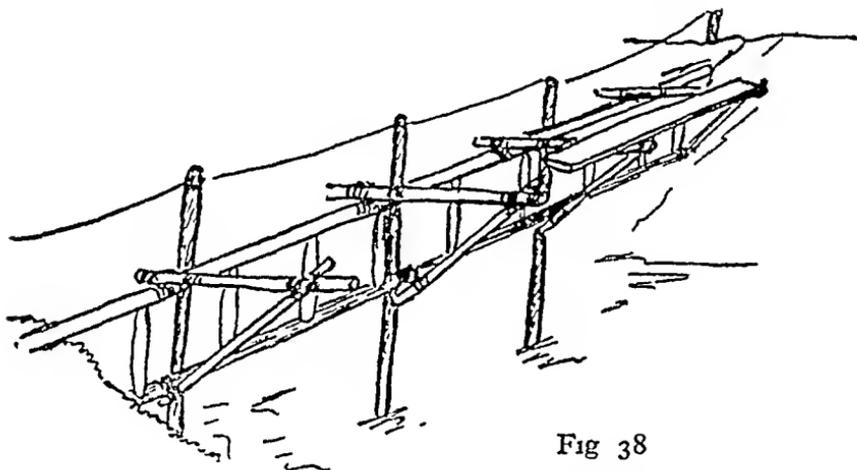

Fig 38

or staffs can be driven into the bed of the stream, and connected up with a stout cord to form the handrail.

If two ladders are available, a more solid and wider bridge can be erected. The ladders are laid across the stream, each set on edge in slots in the banks. Road bearers are then lashed across between the two at frequent intervals and planks laid on these, handrails being constructed as before. If a number of short pieces of board are available these can be laid across, side by side, from ladder to ladder. For temporary and light traffic, nothing else need be done. For work of a longer and heavier duration, these boards should be lashed down. The best way to secure this is to run a light pole above the boards and each ladder. The pole is lashed firmly to the side of the ladder, securing the boards in the process.

The Light Pole Bridge

A very common form of bridge, found in many parts of the world, is built of a succession of sheer-legs. In India, for

instance, bamboo is widely used for this purpose, and, in times of flood, such bridges can be quickly put up and carried for a considerable distance

Hop poles, or other light poles, some 10 or 12 feet in length and about $1\frac{1}{2}$ inches across are suitable for this purpose, but Scout staffs can also be used. Two poles are lashed together 2 or 3 feet from the top with a sheer lashing, another is lashed to the butts by square lashings as a ledger. The distance between the butts when the legs are spread out and lashed apart should not be more than one-third of the height of the legs. Another pole is then placed above the fork of the sheers, at right angles to them, to form the roadway, and is tied to one of the poles with a square lashing. A fifth pole is then attached

to the top of one of the sheers with a square lashing to form a handrail (Fig 39)

This constitutes a bay, and the bridge is built out from the bank bay by bay. The handrail of the first bay should be secured to an upright post on the edge of the stream or pond, and the end of the footway secured to the bank by a couple of pegs. When the first bay is secured and settled, the second bay is carried along it and pushed out into position from the

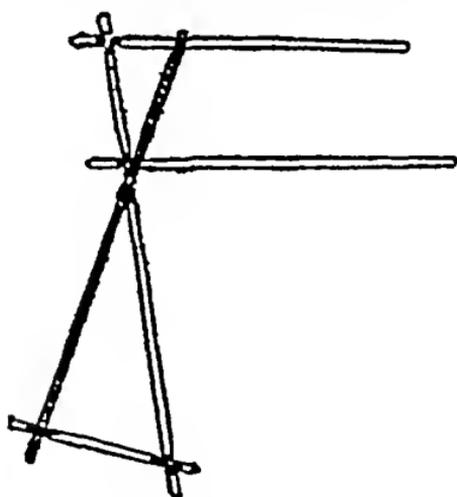

Fig 39

far end, using the ends of the handrail and footway as levers to work with. These ends are then secured to the sheer-legs of the first trestle, the end of the footway by a square lashing on the opposite sheer-leg, and the third bay is carried out. It is easier to sink the legs if the feet are weighted.

It will be obvious that this kind of a bridge can only be built over shallow water, and where the bottom is not too soft. The space between the bays should be about 6 feet, and the handrails and footways should be securely lashed. A light rope can be carried along the tips of each trestle on the other side from the pole handrail, being looped with clove hitches over the ends.

It will be found more convenient to work with shorter lengths of light pole for the ledgers of the trestles, 4 to 5 feet being sufficient for each, but, if ground is soft, a long ledger will keep the trestle from sinking in too far.

A slight variation of this bridge is shown in the illustration (Fig 40), where the first two pairs of supports are driven stakes, the second two supports ordinary trestles and the

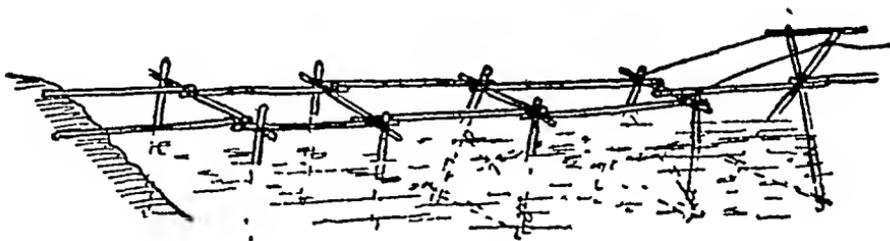

Fig 40

remaining supports sheer-legs. In a long bridge of this nature an occasional 4-legged trestle (see p 66) is a great strengthener.

The Scout Transporter

What, for want of a better name, is called the Scout transporter can readily be constructed for crossing a small river or dyke, provided two long light poles can be procured

The poles are lashed to form sheer-legs in the usual manner,

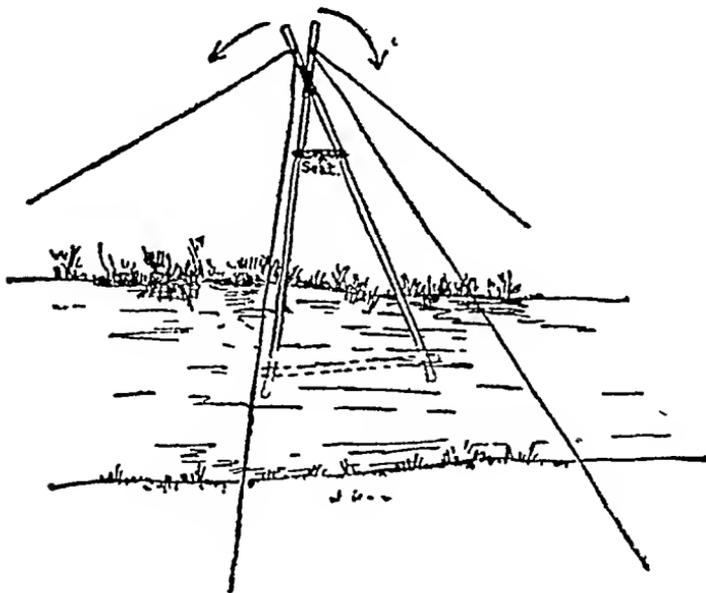

Fig 41

with a ledger lashed across near the butts. A seat is made near the cross by a figure-of-eight lashing from leg to leg, and two fore and two aft guys are attached to the tips of the sheer. The butts of the spars are then placed in midstream, and

should be previously weighted so that they will sink easily and hold firmly in position. A small Scout then sits in the seat, and is pushed by means of a forked pole until the sheers are upright. The strain is then taken on the aft guys, and he is lowered carefully to the other side, where he proceeds to drive in the pickets for the fore guys which he has taken over with him. The transporter is then hauled backwards and forwards till the Scouts are across (Fig 41)

This sounds a very precarious and uncomfortable way of crossing a stream, but it can be great fun, and for years has been a great feature of the Scouters' Training Camp at Ommen in Holland

The Catamaran Footbridge

If several barrels are available a light footbridge can be constructed by using a series of catamaran rafts (p 45). The side pieces should be lashed on to the barrels so that they project 2 or 3 feet in front, a plank roadway being laid across these. The long ends of the side pieces need not be splayed out as is necessary in case of a raft, and can be lashed on to longer poles put end to end. A rope handrail can easily be erected.

If there is a current, the bridge will need to be anchored to prevent it drifting. The easiest way to do this is to stretch a rope, quite taut, from bank to bank, and to attach the back of each catamaran to it.

CHAPTER IX

TRESTLE AND LOCK BRIDGES

"In the Army they are generally made of poles lashed together"
(*Scouting for Boys*)

WHEN it comes to the question of trestle and lock bridges a good deal more is required in the way of study, calculation, preparation and care before the job can be taken in hand. This type of bridging may be regarded as a development of the lighter, and possibly more amusing, types that have so far been suggested, and provides real slogging work of a much more permanent character. Again, this kind of pioneering is much more suited to Rover Scouts than to the average Scouts, as it usually involves the use of much heavier materials in the shape of spars.

The normal Scout Troop should be quite satisfied if, at one

time or other, it has built the majority of the rafts, ropeways, light bridges, and other means of crossing water that have already been mentioned, so that these heavier bridges can be left to the Rover Scout Crew as a development of previous Scouting. Such work is not beneath Rover Scouts, it is real pioneering, and will give them quite a fair amount of exercise for body and mind, and will help to emphasise the need of team work, steady application and discipline—all points that need stressing to-day in the world. On jobs of this kind—or on any pioneering job for that matter—there is no room for slackers.

The more advanced questions of stresses and strains enter into the calculations that are required in setting up a proper trestle or lock bridge that is going to carry traffic of any weight. The Rover Scouts should be encouraged to study the theory of the subject, so that they become more than labourers at the job. Definite lectures on the subject of bridging and its development up to modern times will be both interesting and educative.

The Parts of a Trestle

It is necessary in the beginning to learn how a trestle is built up and to be able to name the various parts properly. Fig 42 shows a typical trestle with the parts named. The diameter of the spars given are suitable for a 15-foot bay and a 15-foot height of trestle. This will be about the largest size with which Rover Scouts may expect to work. The types of lashings to be put on the various crossings are named, although the lashings themselves are not shown for sake of clearness. The way these lashings are made has been described in Chapter III.

The type of spars required for other spans and heights may be calculated as follows:

Transom—10-inch diameter for 10-foot bay, increasing by $\frac{1}{2}$ inch for every 2 feet increase in span of bay.

Legs—Reduce by $\frac{1}{2}$ inch for every foot decrease in height with a minimum diameter of 6 inches. With a span of 10 feet the legs can be $\frac{1}{2}$ inch lighter than with 15-foot spans.

The slope of the legs should be 1 in 6, and can easily be obtained by first marking the points where the legs are to cross the transom, and then adding to this distance apart one-third of the height of the leg from the transom to the ledger when marking the latter.

Choosing the Site

The selection of the site is as of much importance in a bridge as in a camp. In this case the points to be taken into

consideration are the nature of the bed of the stream, the speed of the current, and the nature of the banks. It is obvious

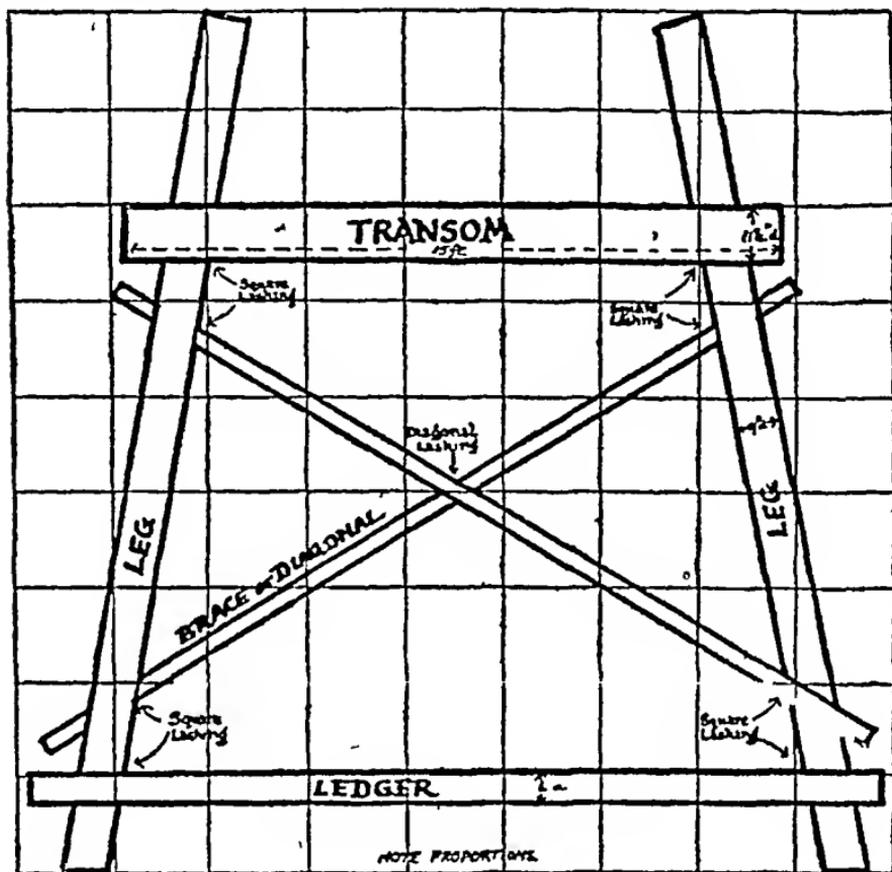

Fig 42

that it is desirable that the bed of the stream should be hard rather than muddy, so that the legs of the trestles do not sink

in too far. In order to find the average speed of a stream, drop in a cork or twig and see how long it takes to travel 10 yards. This will give you the speed of the river in yards per second, four-fifths of this is the average speed at which the stream is flowing. A stream flowing over 4 miles an hour

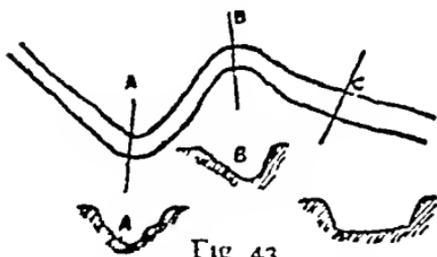

Fig 43

can carry a float across to the other bank by acting obliquely on it. On the nature of the banks, low or high, will depend

very much the height of the roadway of the bridge above water, and the type of approach used

The current of a river flows faster at the outside of bends and the water is deeper there. If Fig 43 is studied it will soon be obvious that point C is the most suitable site to select for a bridge

Calculating the Measurement of the Trestles

Having chosen the site, the next thing to be done is to decide how far apart the trestles are to be placed. This naturally depends on the length and strength of the material available

If the bed of the stream is irregular, the trestles will be of different heights. The

easiest way to ascertain this is to stretch a line from bank to bank. At the same distances apart as the trestles will come, pieces of string are tied to the line and sound-

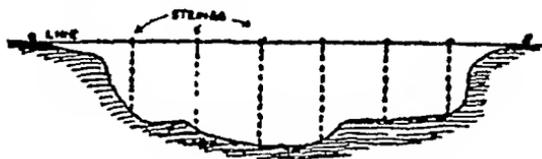

Fig 44

ings taken to the bed of the stream at these points (see Fig 44). This will give the normal height of the transom above the bed of the stream. It is then best to make out a table showing the lengths of the legs of the trestles after this manner

	Trestle No	1	2	3	etc
Normal height of transom		-	-	-	
Allow for sinking in mud according to nature of bed		-	-	-	
Allow for loss of vertical height (slope of 1 in 6)		-	-	-	
Allow for camber of roadway (rise of 1 in 30)		-	-	-	

Height of Transom on leg		-	-	-	
Height above transom at which handrail will be lashed		-	-	-	

	Total length of leg	-	-	-	

All bridges should have a camber, that is, a slope from each bank upwards to the centre. The usual slope is 1 in 30, that is, a 1-inch rise for every 2 feet 6 inches of length

Having obtained the heights of the trestles, the next step is to lay the spars out on the ground, and mark the points where the lashings will come. This procedure is most important in producing a properly squared-up trestle, and should be insisted on from the very beginning

If the bed of the stream is muddy, the ledges should be lashed on as low down as possible. If the ground is very soft, two ledgers will be more effective in preventing sinking, lashed one above the other on different sides of the legs

Constructing a Trestle

The frame is then lashed by means of square lashings with the transom and ledger on the same side of the legs (As will be explained later, this does not hold good for a trestle that is to lock with another) The tips and one butt of the two diagonal braces are placed on the opposite side of the legs to the ledger, the other butt being on the same side. The butts of the diagonal braces are then lashed to the legs by square lashings. The trestle is then squared, the tips of the diagonals forced into position, and lashed to the legs with square lashings. Finally the two diagonals are braced together where they cross by a diagonal lashing. The trestle should then be tested to see that all the lashings are firm, and that there is no motion of any of the spars.

Launching the Trestles

The first trestle is then placed in position and kept vertical by guys until the two outer road borers have been lashed to

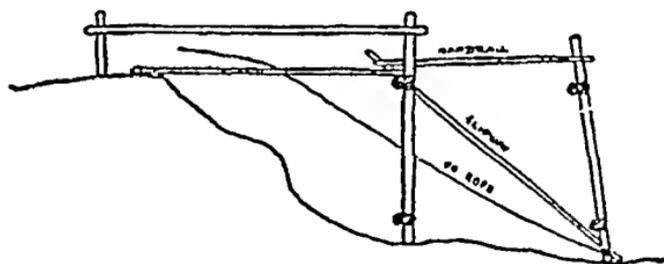

Fig 45

the transom by square lashings and anchored to the bank. If handrails are first lashed to the tips of the legs, the setting up of the trestle will be greatly facilitated.

In order to launch the trestles a spar, or better still two, one on each side of the bridge, is used as a slipway. The slipways should rest on the bed of the stream a little beyond the point where the trestle will stand (Fig 45). Footropes are attached to the butts of the legs, and handrails to the tips. The trestle is carried forward and launched down the slipway by easing on the footropes. When the legs are on the bed of the stream, the footropes are held or made fast, and the handrails pushed out until the trestle is upright. The handrails are then lashed to the previous trestle, road-bearers run out and lashed and the roadway built.

Building the Bridge

In this way the bridge is built up bay by bay, and the roadway completed as the bridge advances. The roadway consists of decking carried on road-bearers of timber or other material carried on the transoms of each trestle. The number and size of the road-bearers depend on the length of the span as well as on the traffic that the bridge is to carry, and they are spaced evenly over the width of the roadway, which has to be a clear 9 feet if wheeled traffic is to cross over the bridge.

The decking usually consists of planks 3 inches thick and laid across the road-bearers with gaps of $\frac{1}{2}$ inch between each to allow for drainage. The decking should be fastened to the outer road-bearers and should not project more than a few inches beyond them. Earth should not be scattered on top of the decking. If the bridge is to be used by horse traffic, straw, rushes, etc., should be scattered on top to give a footing.

If the bridge is a long one, diagonal braces should be lashed every now and then between the pairs of trestles, so as to give the bridge more stability.

The approaches to the bridge on both banks should then be made good, and any inclines modified if necessary.

(In describing this type of bridge, we have purposely gone the whole hog, so to speak, and indicated the uses to which this type of bridge can be put. It is understood, however, that a Rover Scout Crew will be very limited as to the type and quantity of material it can obtain. Whatever these may be, the principles of construction remain the same, and it is better to describe a real bridge than a mere trumpery affair.)

Lock Bridges

Locked trestles are used as a substitute for an arch where trestles cannot rest on the bed of the obstacle. One trestle is made on each bank. The legs are laid out butts to the bank, and legs, ledgers and transoms are marked where they cross each other. The trestles are, however, constructed differently from those for the trestle bridge described above. It will make it clearer if these differences are tabulated thus:

	Trestle bridge	Lock bridge
Ledger	on same side of leg as transom	on opposite side of leg to transom
Diagonals	2 tips and 1 butt on opposite side of leg to ledger	2 butts and 1 tip on same side of leg as ledger.
Legs	at a slope of 6 over 1	at a slope of 20 over 1.

For lock bridges the trestles are always launched with the transom towards the bank.

Single Lock Bridge

For a single lock bridge one trestle must be narrower than the other so that it will lock in between the legs of the wider one. This entails careful measurement of the diameter of the legs of the trestles beforehand.

Before starting to build it is necessary to lay out a section of the gap to be bridged on the ground with pegs and sisal. From this section it will be an easy matter to mark the legs of both trestles where the transoms are to be lashed. The transoms themselves should then be marked so that the tips of the legs will eventually lock over each other and not foul. Each trestle is then laid out as advised in the case of the trestle bridge, and marked and lashed in similar fashion. Meanwhile footings are prepared in either bank, by digging holes, placing rocks in position, or otherwise.

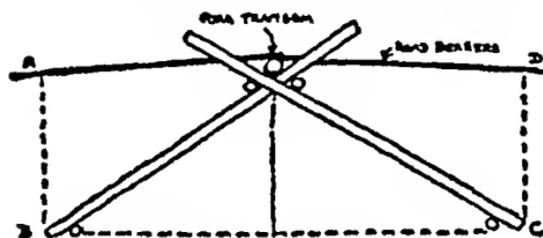

ABCD - SECTION OF GAP LAID OUT ON GROUND

Fig 46

The trestles are launched by lowering the butts into the footings by means of footropes, and the trestles lowered gradually towards the centre of the gap by guy ropes until they

lock. If proper care has been taken in the preliminary measurements and markings there should be no difficulty in this. The fork transom (Fig 46) is placed across the two frames and the road-bearers laid on it and lashed in position. The staging, or chesses, is then laid across these and lashed down—a light pole, or riband, being run out over the outer road-bearers in order to keep it in place more securely. Staffs can be fixed on the banks and lashed to the ends of the fork transom in order to carry a handrail.

Double Lock Bridge

A wider gap can be bridged with a double lock bridge. In this case the two trestles do not lock together, but are held apart, and the middle bay formed by two distance pieces, one on each side of the bridge.

To start with, a section of the gap is laid out on the ground in the same way as for a single lock, and the trestles built in the same way, with the exception that the measurements of the trestles are exactly the same, since they are not going to lock into each other.

The trestles are launched in the same way as for a single lock bridge, and the tops are paid out on the guys until the trestles are in their proper positions. The guys are then made fast, and the distance pieces run across and lashed to the transoms of the trestles, road transoms being placed in position as indicated in Fig 47 and lashed. The roadway is then completed.

If the distance pieces are heavy, they can be hauled out over the nearest transom by means of a block attached to the tip of the trestle leg, the block being then transferred to the tip of the far trestle.

A very important point in lock bridges is that the trestles must never lay over at a greater slope than 2 over 1. If there

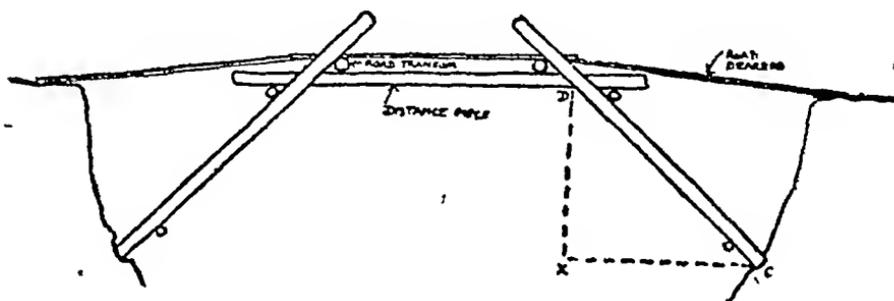

Fig 47

is any doubt at all as to the strength of the trestles, it is a safe rule that CX in Fig 47 must not be greater than DX.

It can now be appreciated that the building of bridges with trestles involves a considerable amount in the way of theoretical as well as practical knowledge, and that it is a pioneering exercise of a more advanced form. This, however, should not prevent Scouts from building trestles with their staffs and other light material chiefly by way of practice in lashing.

CHAPTER X

FLAGSTAFFS, SIGNALLING MASTS AND TOWERS

“An old scout is full of resource” (*Scouting for Boys*)

So far our pioneering exercises have mainly concerned themselves with the question of transport from place to place, over water or otherwise. Now we can turn our attention to the

construction of masts and towers so as to give height above ground for various purposes. In building these, lashings are of just as great importance as in the building of bridges, in addition there is the question of stability to be considered. Any unequal distribution of weight, any divergence of the centre of gravity from the central line of the structure will sooner or later lead to collapse. Any tendency in the structure to bend will quickly lead to breakage.

Camp Flagstuffs

The simplest form of erection is probably the setting up of a flagstaff in camp. It is a mistake to take to camp a ready-made, white-painted flagstaff, provided there will be sufficient materials available to build one on the spot. After all half a dozen extra Scout staffs will make quite a suitable flagstaff, the bundle will be easier to carry, and they will not cost so much as a shop-made article. There are various ways of constructing a flagstaff from staffs, but it will suffice to suggest two different methods here, and to mention another method suitable for a competition at displays later on in Chapter XIII.

The first method need not involve the erection of guy lines, but will not give much in the way of height. This flagstaff stands on its own legs, so to speak, three of the staffs being lashed so as to form a tripod on which the mast stands.

Select the three stoutest staffs and place them together, butts at the same end. Place another staff in the middle of the three with its point projecting at least a foot beyond the points of the other three. Lash the four staffs together by a sheer lashing at a point some six inches below the points of the three. Pull out the butts of the three staffs until they form a tripod, and the butt of the fourth staff rests on the ground in the centre of the triangle. The butts can be let into the ground, or a cord can be attached to the legs of the tripod so as to prevent them splaying too far, the legs being evenly set out at angles of 120° . The other two staffs should be placed together so that the butt of one overlaps the tip of the other by 18 inches. Two sheer lashings are then placed round the two staffs where they overlap, the lashings being about a foot apart. Wedges should be inserted into both lashings so as to make them absolutely firm.

To the tip of this elongated staff attach a loop through which a line to serve as the flag halyards should be run. This loop can be formed by making a small bowline at the end of a short piece of cord which is attached to the end of the staff with a rolling hitch. These two staffs are then taken and lashed

firmly, butt end down, to the staff which projects beyond the top of the tripod. Again two sheer lashings should be used, and they should be firmed by means of wedges. The flagstaff is now ready for use, and should stand quite firm, if the staffs have been properly lashed and the legs of the tripod evenly set out (Fig 48)

A flagstaff of this nature can be constructed and set up indoors for purposes of a display or otherwise

The second type of flagstaff depends for its stability on guy

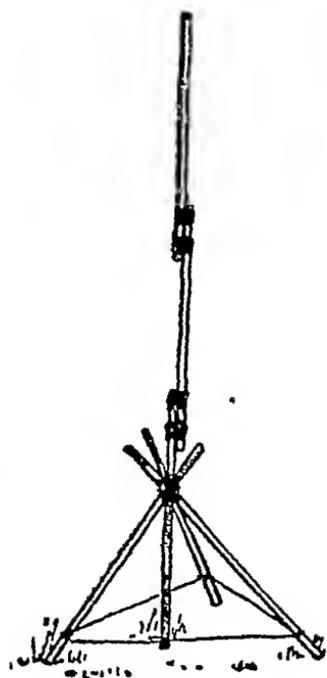

Fig 48

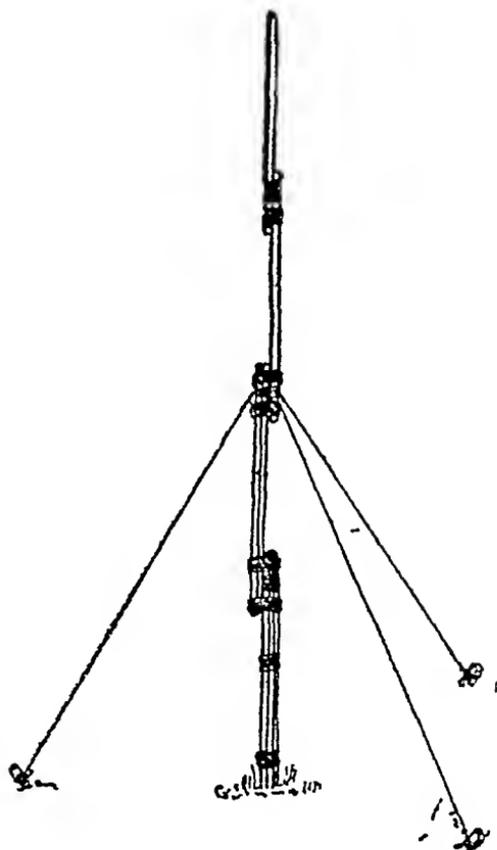

Fig 49

lines. First lash three staffs together by sheer lashings at the butts, at the tips and in the centre. Lash two more together, butt to tip. Then proceed to lash these two on to the tips of the first three, overlapping the two bundles and lashing them as described in the first flagstaff. The sixth staff can be added on, and a seventh, too, if available, so that if the staffs are all 5 feet 6 inches long, a flagstaff of 17 feet 6 inches is available. If there are only six staffs, it is possible to utilise two instead

of three at the bottom, and so achieve the same height. Halyards are attached to the top, and three guy lines to the middle joint of the flagstaff. When the flagstaff is set up, the butt should be sunk slightly into the ground, and the guys taken out at equal angles and pegged down (Fig 49). If the guys are attached to the pegs by a guy-line hitch, then they can be loosened or tightened easily whenever required.

It stands to reason that the same principles of construction can be applied to poles that are longer and stouter than Scout staffs, and that by their use still higher flagstaffs can be obtained if desired. It has to be remembered, however, that the heavier weights affect stability, and that any departure from the vertical might have disastrous effects.

When heavier poles are used, or when a single heavy mast is available, the flagstaff will probably have to be erected by means of sheer-legs. A single heavy mast will need careful guying, but if a permanent flagstaff is desired guy lines can be dispensed with if the mast is sunk one-eighth of its height into the ground. The erection of such flagstaffs usually proves a pioneering job of great interest as well as great labour! More ambitious pioneers can set about the erection of yard-arms and gaffs in order that signal flags can be run up as well as the country's flag.

Signalling Masts

Sometimes it is desirable to erect some kind of a signalling post so that messages can be transmitted over a longer distance. Trees may be utilised for this purpose, but are not usually very suitable, especially in the summer, so that artificial masts have frequently to be set up. Sheer-legs, the Scout transporter, and even single poles can all be utilised for the purpose.

A single derrick mast is erected in this way. A light spar, 25 to 30 feet in length, is laid on the ground. Four guys are made fast some two-thirds of the way up—two long ropes can be middled and clove-hitched at their centre round the spar. Four to five feet from the top a "cross-tree" some 3 to 3½ feet in length is lashed on firmly by a square lashing. A rope is then knotted with simple or overhand knots every foot of its length, and secured by a rolling hitch to a point 2 feet from the top of the spar. This rope should reach the ground when the spar is erected. A loop, or Bo'sun's chair is then made fast above the cross-tree at a convenient height above it to enable the "look-out" or signaller to lean back without discomfort.

The heel of the spar should be let into the ground some two feet. The erection of the mast is a simple matter, using the guys and manhandling it into an upright position, the butt

being guided into the hole at the same time. The guys are made fast to pickets that have been well secured, and the mast is ready for use. The "ladder" is held down at the foot while the signaller clammers up.

An effective stunt at outdoor displays is to run up a signalling mast of this or other nature. Sometimes a Scout clammers up afterwards to send off a message with his flags, sometimes he gets into position before the mast is erected and is hauled up with it.

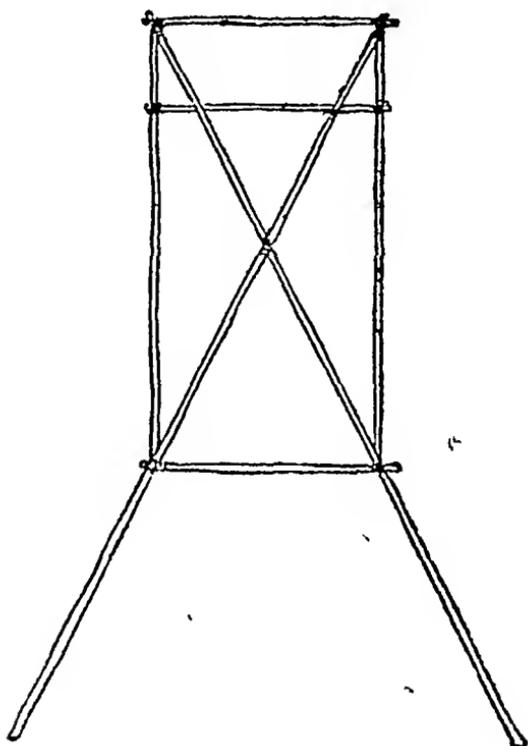

Fig 50

On single masts a "crow's nest" consisting of a barrel without top or bottom lashed above the cross-tree can be used.

A Signal Tower.

In Dan Beard's *Shelters, Shacks and Shanties* a description is given of a signal tower which is well worth while erecting if the materials are available. For this tower 8 poles 16½ feet long and some 4½ inches diameter at the butts, and 4 poles 9 feet long and 2½ inches diameter are required, with, in addition, 26 stout sticks 4½ feet long for braces and the flooring of the platform.

The method of construction is somewhat as follows. This

description is taken in an abridged form from Dan Beard's book which every Scout Group that is keen on pioneering would do well to possess

Construct a frame as illustrated in Fig 50 with 2 of the 9-foot poles and 3 of the $4\frac{1}{2}$ -foot sticks. Then take 2 of the $16\frac{1}{2}$ -foot poles and place them diagonally from corner to corner of the frame, and lash them securely in place, the tips being lashed to the top corners of the frame and the butts projecting

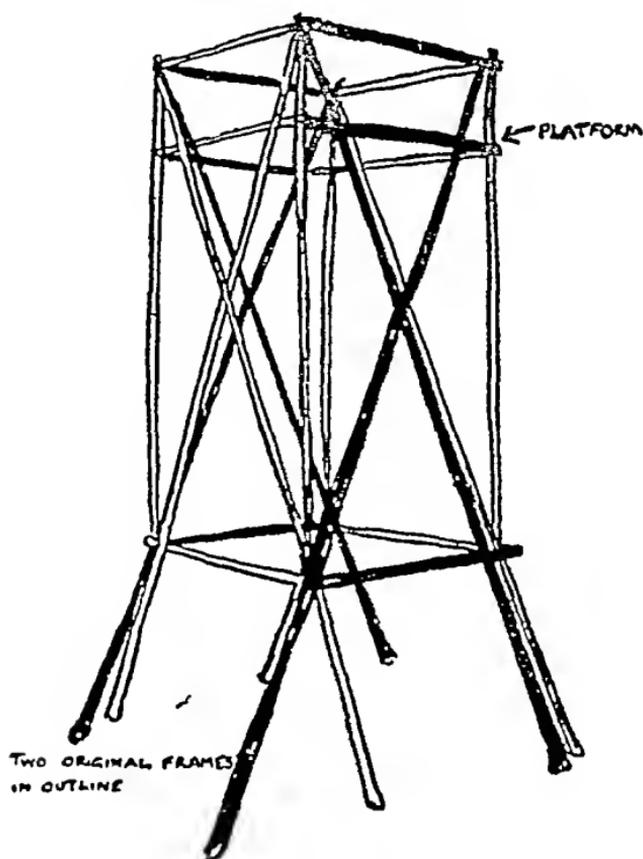

Fig 51

outward below it. Square lashings are used in all cases except where the long poles cross each other when a diagonal lashing is used as usual.

Construct a second frame in a similar fashion. Lay the two frames on the ground with the butts of the long poles pointing towards the other frame and some 5 feet from it. Haul the frames up vertical by attaching guys to the points where the long poles cross and by anchoring the butts—by human or other means. Great care must be taken to see that the frames

are not pulled past the vertical, and it is advisable to attach back guys to prevent this

When the frames are in position brace them together by lashing $4\frac{1}{2}$ -foot sticks across between them at the points where the long poles are lashed to the framework, top and bottom. The remaining 4 $16\frac{1}{2}$ -foot poles are then placed in position, as shown in Fig 51, so that all four sides of the tower are similar. Extra braces are added so as to connect together the long poles which run parallel to each other and strengthen the tower. The platform is built by using the same $4\frac{1}{2}$ -foot sticks for which Scout staffs can be substituted if necessary. A flagstaff can be erected on one side of the platform and a rope ladder added if desired, although it should be possible to swarm up the tower by means of the horizontal braces. A tower of this kind is not so difficult to build as may be imagined, a schoolmasters' training course achieved a very good result in quite a short time!

A Scout Staff Tower

This tower was built for a display at Ilford, the only materials used being a quantity of light lashings and 57 Scout staffs 5 feet 6 inches long

A triangular tower is built up from the ground in this way. First of all a trestle is constructed, using 5 staffs, the ledger projecting 6 inches past the legs and being lashed to them a foot from their butts, and the transom projecting 9 inches past the legs and being lashed to them a foot and a half from the tips (see Fig 52). One staff is then lashed across as a diagonal brace. This trestle forms one side of the first storey of the tower. The ledgers and transoms of the other two sides are lashed into position on the legs of this trestle, projecting 6 inches and 9 inches respectively as before, and are similarly connected to the third leg of the tripod. Diagonal braces are lashed across these two sides, running in each case from bottom left to top right between ledger and transom. The first storey is completed by lashing a staff across the top of the ledgers from where they cross at one leg to the centre of the opposite ledger. This process is repeated for the transoms, but the staff is lashed to a different leg.

The second storey is commenced by lashing other staffs to the legs of the tripod, overlapping the first staffs by half their lengths. Transoms are lashed to these staffs 1 foot 3 inches from the points. Diagonals are lashed across the sides as before, but this time in opposite directions from bottom right to top left, and the triangle made by the transoms is secured by lashing a staff from the third leg to the middle of the transom

on the opposite side. In lashing the transoms on this second storey the ends of the staffs should project a foot beyond the legs in order to preserve their angle.

In the same way subsequent storeys are added, the staffs used for the legs always overlapping each other by half, so that with the exception of the first 2 feet 9 inches and the last 2 feet 9 inches the legs are double thickness. The distance between

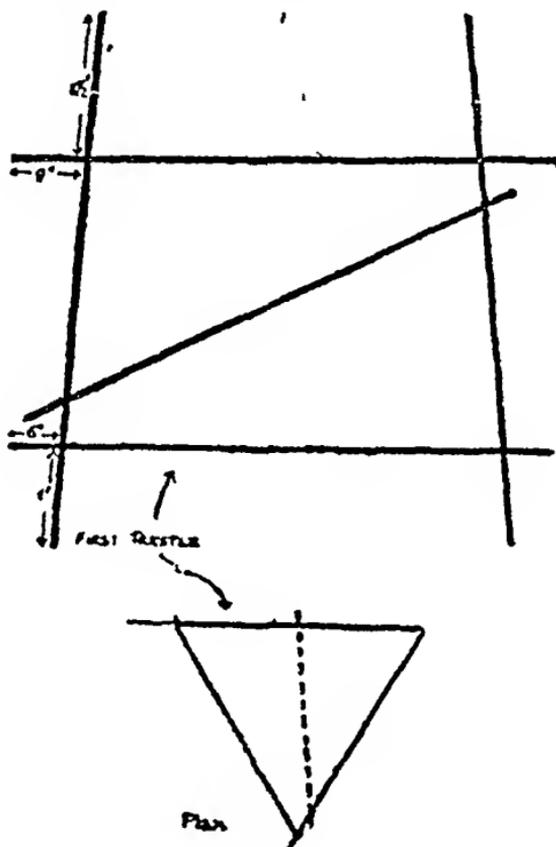

Fig 52

the transoms, or cross pieces, should be 3 feet in the third storey, as in the previous two, but only $2\frac{1}{2}$ feet in the fourth and fifth storeys. The staffs forming the transoms will obviously project further past the legs each time, if the angle of the legs is to be preserved. In the third storey they will project 1 foot 3 inches at each end, in the fourth $1\frac{1}{2}$ foot, and in the fifth 1 foot 9 inches, the last two measurements being approximate (Fig 53). The diagonal braces for each storey should go alternately from bottom left to top right and from bottom right to top left, while the horizontal staff securing the three

transoms should set off from each of the three legs in rotation

The description of this tower sounds somewhat complicated

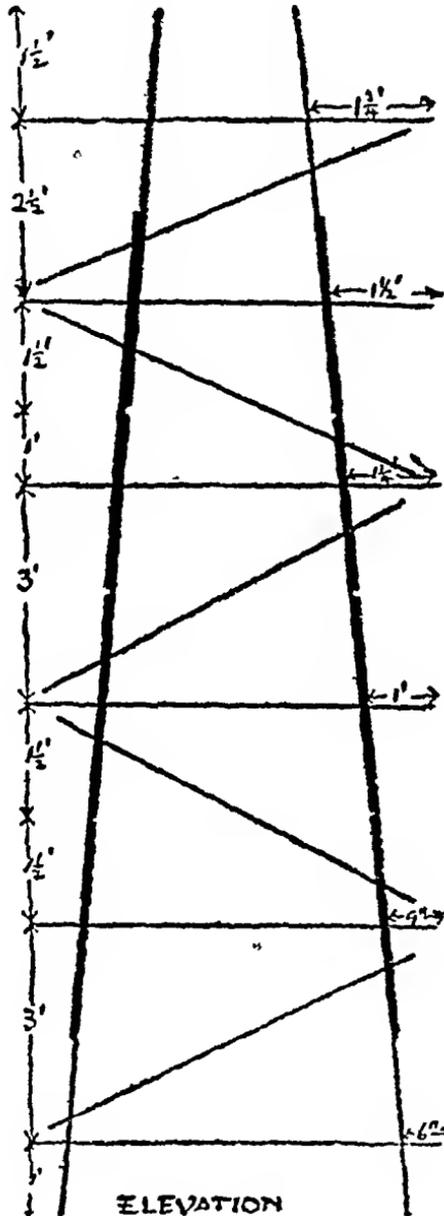

Fig 53

but the actual tower itself is not so difficult to build. It is probably advisable to start building the first storey using double staffs for the legs in order to give strength, so that a

total of 60 staffs would be required, 50 staffs would build a tower of four storeys high, and 40 one of three storeys. The height of the top platform (transoms) from the ground in these three cases is slightly less than 15 feet, 12½ feet and 10 feet.

The Malvern Tower

The Malvern Tower was described by Col H L Stafford in *The Scouter* for November 1923, and is developed from the Malvern bridge described there.

For this bridge 5-foot Scout staffs of a special strength are needed. The staffs are bored together at each end so that they can be bolted together by means of ¾-inch iron bolts. The standard bridge is of five "panels," each 4 feet 6 inches long, 23 feet long over all, but bridges of two, three or four panels may be made. A bridge longer than five panels is not recommended as the stresses would be more than proportionately greater. Slightly modified and strengthened with some extra staffs, the bridge, up-ended, becomes the Malvern tower and can be used for signalling.

There is a good deal of scope for the building of towers by Scouts and Rover Scouts, and this branch of pioneering has been somewhat neglected in the past. It is probably more exciting to bridge a river, but the erection of towers provides a ready answer to those who complain they haven't got a river to bridge!

CHAPTER XI

CLIMBING AND TREE-TOP SHELTERS

"Every boy likes climbing, and if you stick to it and become really good at it, you will go on at it for ever" (*Scouting for Boys*)

BEFORE we come to the erection of tree shelters, a few words on the subject of climbing generally will not be out of place. This, like observation, is one of the subjects on which the Chief Scout is very keen and he has returned to the charge time and time again. In *The Scouter* for April, 1922, he wrote:

"It is natural to the human being to climb. Climbing undoubtedly develops health and strength in a better way than any physical drill can effect, because it is natural, not artificial. But more than this, it develops at the same time such qualities as Self-reliance, Courage, Caution, Endurance, Ambition, Patience, and other elements of character which do not come at all in physical drill.

Later comes the adventure that is dear to every boy, that of climbing trees. Ladders, masts and rope climbing are all valuable to this end, and give practice in towns or playgrounds where space and opportunity are limited. Tree-climbing can be amplified into a sport with the intelligent use of the climbing rope, and thus almost any tree comes within the scope of the boy's climbing power.

Then tree-climbing incidentally involves some elementary knowledge of botany, so that the climber can distinguish the different species in view of their respective climbable properties."

A Climbing Apparatus

Two months later he described a climbing apparatus which the Scouts of Bentley had rigged

Here is a drawing of it (Fig 54)

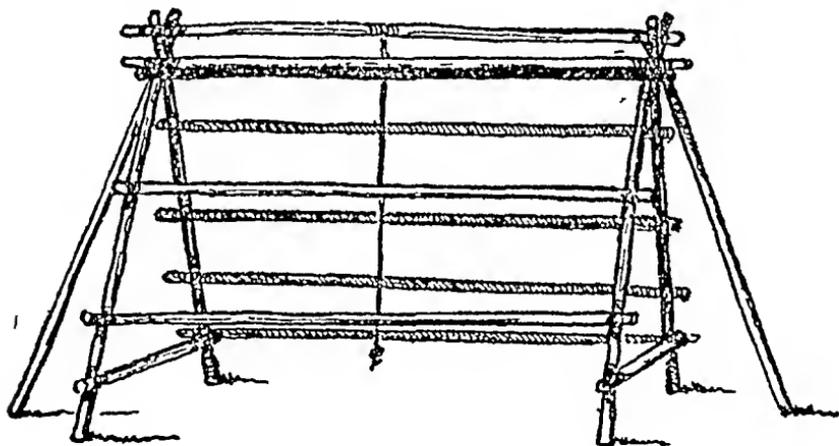

Fig 54

"One side of it gives a form of 'Norwegian ladder' which appeals particularly to Wolf Cubs. It is formed of old hop poles or scaffolding poles, and is built much on the principle of a single-lock trestle bridge, the legs being well splayed out to give stability, which is further increased by supporting struts at each end. All butts are sunk well into the ground. The length is about 12 feet, and height about 10 feet, the legs being therefore about 12 to 14 feet. Distance between back legs and front, at the ground, is about 9 feet. It is a good dodge to have a plank rather than a pole for one of the higher side bars, in order to give practice in hanging on by the fingers.

"The number of exercises and stunts that the lads can devise on this apparatus is astonishing—including team obstacle racing, swinging by arms or legs, walking the plank at a low altitude and increasing up to 10 feet, swarming and moving

along hanging by the hands or by hands and legs Climbing ropes can be suspended from the top bar, and swinging can be practised on these from one point to another ”

Climbing Ropes

In order to get up a tree which is devoid of low branches it may be possible to sling a rope over the nearest reliable branch This is most easily done by throwing over the branch a stone attached to a piece of cord, the other end of the cord being tied to the rope which can thus be hauled over the branch The rope must be long enough for both ends to come within reach of the ground at the same time, and is best secured to the branch by a running bowline The climber can either swarm up the rope or use it to aid him to “walk” up the trunk of the tree Inexperienced climbers may find it necessary to use a knotted rope which will give them more purchase Overhand knots or figure-of-eight knots are suitable for this purpose, the latter being preferable if the rope is long enough If, however, the rope is subjected to any severe or prolonged strain, these knots will be difficult to undo unless stout sticks are inserted into the middle of them Overhand knots can easily be made by picking up at regular intervals on the rope a series of half hitches, the end of the rope is then passed through all the hitches which are drawn through each other to form a succession of overhand or simple knots

Tree-climbing with ropes is a useful exercise for any Scout Troop or Rover Scout Crew, for the reasons suggested by the Chief Scout, and it also affords practice for rock or Alpine climbing later on A certain amount of preliminary climbing practice is essential before it can be hoped to erect any kind of a shelter at any real distance above the ground

Ladders

Ladders of different kinds are an advance on climbing-ropes as affording more hand and foot room The climber is not then dependent on his own strength so much to haul him up, but is supported by the rungs of the ladder If, therefore, it is intended to build tree-top shelters of any kind, it is advisable to think out the construction of the ladders (Fig 55) to reach them first of all The normal ladder consists of two long uprights connected by rungs or cross-pieces which form steps What is frequently known as a “hen ladder” can, however, be made with one upright

If the upright is a long pole, this has cross-pieces lashed to it every foot If a rope is used for the upright then short lengths

of stout sticks are secured to it at the same intervals by marline-spike hitches. A single rope ladder is a somewhat precarious means of ascent, and a two-rope ladder should be constructed if possible. This is made in the same way, the ends of the rungs being inserted into marline-spike hitches on the two ropes at equal distances of about a foot. If a nick is made in the rungs near their ends, they will be gripped more securely by the hitches. The ropes should be knotted together at both ends of the ladder. The top end is hitched over a convenient branch by the most suitable knot or hitch—this is dependent on circumstances, in many cases a non-slip loop being best. The bottom end of the ladder should be anchored down to the ground by a large stone, a log, or by pegs driven into the ground, since it is easier to climb the ladder if both ends are secure. A rope ladder can be pulled up easily from

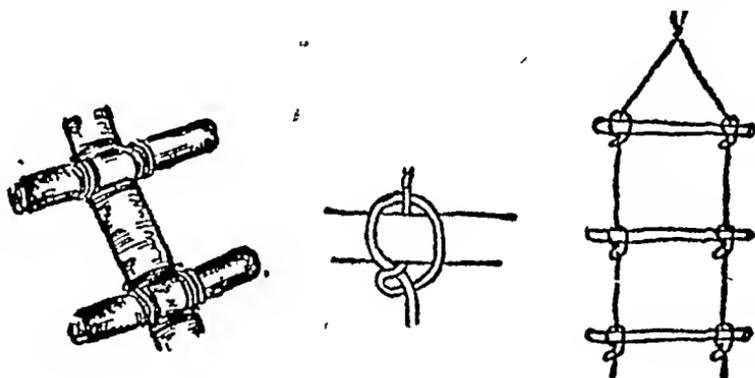

Fig 55

above, and one's eyrie rendered safe from attack, but there are difficulties in the way of removing it when the owner is out.

A pole ladder can as obviously be reared from the ground, and hidden when the owner of the shelter is away from home, but it is a difficult matter to draw up after one.

There is no need to explain the building of a pole ladder as it merely consists of a number of short lengths of timber lashed across long poles at equal distances by square lashings. It is usually advisable to have the poles forming the sides of the ladder spread wider at the foot than at the top.

Selecting Trees

If we are setting out to build a tree shelter, the choice of the particular tree or trees must obviously be the first consideration. This choice is influenced by the type of shelter, the purposes for which it is to be used, and the height desired above ground. Certain trees, such as elms, must be scrupu-

lously avoided, as being dangerous for the purpose. Other trees, such as oaks, will afford suitable platforms of themselves, although usually not very high from the ground. Other trees, such as pines, may grow so close together that it is possible to utilise two, three, or even four as pillars on which the shelter is built. In order to build a tree shelter one must make one's plans to fit the tree every time.

If a den or hidy place is desired anywhere above ground, it is best to look for an oak whose branches spread out from a low central bole. If a suitable floor for a shelter does not readily exist, it can easily be contrived by lashing one or two

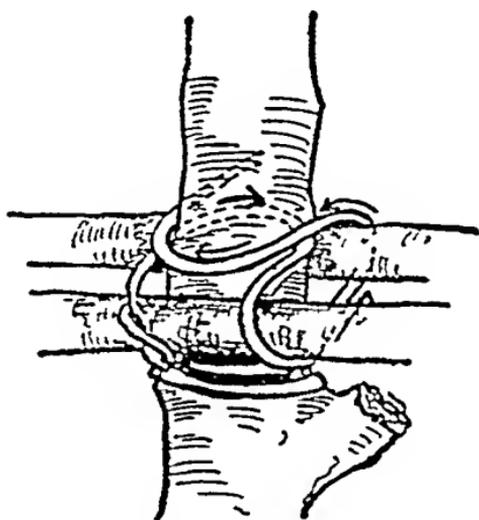

Fig 56

poles between the branches. In most cases, however, foundations for the shelter will have to be erected.

Building the Floor of a Tree-top Shelter

The platform on which the shelter is to stand is obviously the first part to be constructed. The general plan to be adopted for a one-tree shelter is somewhat as follows. If the tree is a living one, lashings must always invariably be used instead of spikes and nails, which would give a securer foundation but might damage the tree. This is a limitation which we must be prepared to face.

Lay a couple of stout poles on either side of the trunk, above a projection or bulge in the trunk if at all possible, and lash them firmly to the trunk, separately or at the same time. If each pole is to be lashed separately, a square lashing will do. If the two are being lashed at the same time, secure the lashing

to the trunk in the usual way below the two poles. Pass the lashing in front of the near pole, over the top and round the trunk, then over and under the near pole on the opposite side of the trunk, straight under the far pole on the same side, up and round the trunk again the opposite way round, then over and under the far pole on the other side, and back under the near pole at the point where the lashing first started. Fig 56 will help out this somewhat complicated explanation. This process is repeated several times, frapping turns are then put

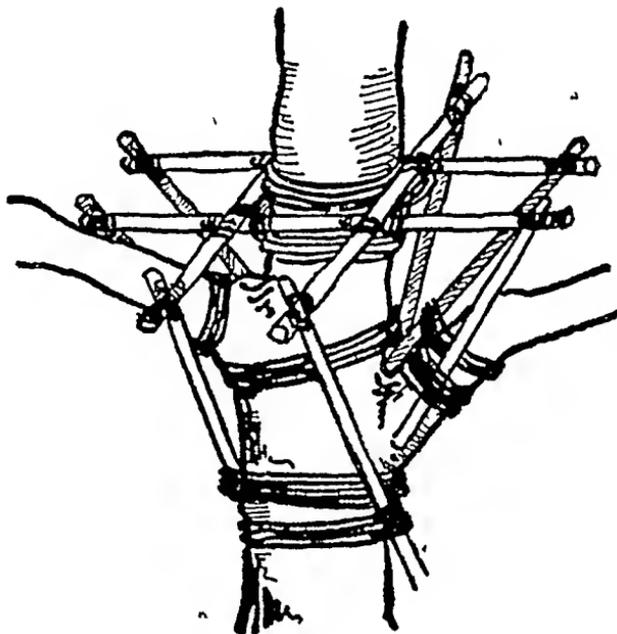

Fig 57.

on between each pole and the trunk, and the lashing finished off in the most convenient way.

Another two poles are lashed across the trunk above and at right angles to the first pair.

Four other poles are then lashed to the ends of the first four and brought down to the trunk and lashed firmly there to act as braces. It may be possible to place the lower ends of these braces against lower branches of the tree so as to give them more purchase (Fig 57).

The foundation for the floor has now been made. Other poles can be laid across, and supported at the ends by other braces.

If two, three or four trees are available, the joists of the floor should be lashed to them in the most convenient manner,

and poles lashed across the joists until a suitable floor has been made

Building the Shelter

After the floor is laid over the joists, and has been tested to see if it is thoroughly secure, any form of shelter from a rude, open shed to a rain-proof hut can be erected upon it. There is scope here for ingenuity in making use of the existing branches of the tree, in suiting the shelter to the foliage, and in elaborating by degrees, until a regular Wendy hut in the tree-tops is, possibly, secured (Fig 58)



Fig 58

Uprights for the walls can be lashed to the edges of the platform and secured to the framework of the roof above, the middle rafters of which can be lashed to the trunk in the same way as the floor joists. If more than one tree is being utilised, then these trees will provide corner or side posts, and the construction of the walls is correspondingly easier.

It is also possible to construct light hurdles and utilise them both for the walls and for the roof of the tree shelter. In this case the building, once the floor has been laid, can be carried out in accordance with

one or other of the suggestions contained in the next chapter for the building of camp shelters on the ground

Hauling up Materials

One of the difficulties to be overcome in the building of a tree shelter is the hauling of materials to the height desired. A single block will usually be found sufficient. This should be suspended well above the required height, and should be worked as far as possible from the ground level. A light guy should be attached to the load so as to guide it on its way up. Poles and timber will have to be slung vertically by means of a killick hitch (timber hitch and half hitch), scaffold hitch (see p 26), sling, or even bottle hitch.

Tree Dwellings.

It is not possible to do more than just draw attention to the possibilities of tree shelters. Primitive peoples in all quarters of the world have built tree dwellings, and some in India and the Pacific islands do so to-day. Climbing and the building of tree shelters is always a great joy to boys, and grown-ups are not above a desire to taste of these same joys. There is no reason why we should not utilise the Scouts' desire to climb higher practically as well as metaphorically. It is true that some small risk is involved, but I have already endeavoured to show that such risk is frequently to be desired as helping to build character properly. There is no reason that any great danger should attach to climbing or to the building of tree shelters provided ordinary precautions are taken and proper discipline and obedience of orders is insisted on.

Boys of Scout age are quite able to look after themselves in these matters with a little advice, and in the past have proved that they can do such things as these without falls or other accidents. Grit is still needed to-day, and we should not run away from opportunities of exercising it.

CHAPTER XII

CAMP SHELTERS

“To live comfortably in camp a scout must know how to make a bivouac shelter for the night, or a hut if he is going to be for a long time in camp” (*Scouting for Boys*)

Boys, and frequently girls too, instinctively turn to the building of huts and houses out of any materials that they may happen to find lying about. The Scout can turn this instinct to good account in his camping and in his pioneering, and will find useful and pleasurable employment. Many of us, however, never get further than the bivouac shelter illustrated in *Scouting for Boys*, and we fail to see that this is merely a suggestion to encourage us to go and make further experiments for ourselves. It is worth our while, therefore, to describe the development of hut building in history. This can be found in *Everyday Life in the Old Stone Age*, by Quennell.

Darwin refers to the Fuegian wigwam which “resembles, in size and dimensions, a haystack. It merely consists of a few broken branches stuck in the ground, and very imperfectly thatched on one side with a few tufts of grass and rushes”

The Tasmanians made much the same form of shelter, using bark instead of grass and rushes. This was the earliest form of house, and in the open-air circles of to-day is generally known as "wind-break" shelter.

The next development occurred when two wind-breaks were leant together so as to form a rude, small hut. These were made of any rough branches that came to hand, and its modern prototype is the wedge hike tent, open at both ends.

Neolithic Dwellings

The Bushmen of South Africa constructed their huts, much as the gipsy does to-day, with a framework of bent sticks covered with skins. Eleven thousand years B.C. these were improved on until they resembled the dwellings illustrated in Fig. 59. "This round beehive form, made perhaps of willow withies, would have been weak in the crown, if the tent was of any size, yet it could be constructed very simply anywhere that saplings were found. Almost all the early hut builders seem to have dug a hole in the ground of circular shape. The earth removed was heaped up round the outside. In the centre of the hole a roof-tree was set up, formed of the trunk of a tree, with a fork perhaps left at the top. Around this saplings were placed, their feet stuck into the surrounding mound, with the tops leaning against the roof-tree. These formed the rafters, and if in between these were interlaced smaller boughs, it is quite easy to see that the whole could be covered with skins or rough grass thatch. Quite a comfortable house could be made in this way, and we know that it is a type which was general in Neolithic times.

"Other Madeleine drawings suggest a form of hut which is constructed by the North American Indians."

Fig. 59 "also shows the skin tent which the Eskimo uses on his summer wanderings. The diagram shows how the tent is made with poles and covered with skins, the front portion being of membrane to admit light. Large stones serve to hold down the skins" (*Everyday Life in the Old Stone Age*, pp. 93 and 94).

Even this brief extract is sufficient to show the interest that lies in going back to trace the development of shelters as well as of men and animals. In this way the Scouter is afforded scope for imagination, and illustrations which he can use to encourage his Scouts in the making of things to-day. There is added the interest that these primitive forms of buildings are still found thousands of years later, as in the case of Eskimos and gipsies, and supply the structure on which more modern shelters and tents are built.



WIND BREAK



AUSTRALIAN



TWO WIND BREAKS



PALAEOLITHIC



10,000 BC



MODERN LAP (Turf and Logs)

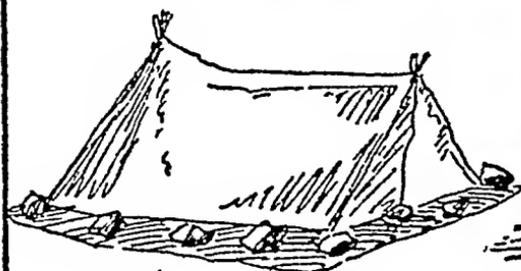

ESKIMO (SUMMER)



BRITISH (WATTLE)

Fig 59

Simple Shelters

In constructing quite simple shelters there is the choice of three different types—the wind-break, the wedge and the conical

The construction of a wind-break is obvious from the illustration in yarn 8 of *Scouting for Boys*. The materials used depend entirely on what is available, and the size of the shelter is governed by the materials. If suitable forked sticks for the uprights are not available, then the cross-piece must be lashed to the uprights. Other branches or poles are leant across the upright from the ground, and lashed into position. If the butts of these leaning sticks are sunk into the ground, the shelter will obviously be more stable. Lighter branches are then lashed across the leaning sticks at suitable intervals, and the shelter covered by any material that is available. Grass, rushes, bracken, straw and heather can all be used to thatch the lean-to. The thatching should start from the bottom, and each layer should overlap the one below it. If bracken or heather is used, the stalks should point upwards. The thatch can be worked into the framework, or held in position by lashing it down with sisal. It is very often advisable to secure the thatch more firmly by lashing light sticks at intervals of some 10 inches right across it. The triangular sides can be left open, or filled in with sticks and thatch.

The Adirondack shelter favoured by Daniel Boone is merely an enlarged form of this model.

When a second lean-to is built up on the opposite side of the cross-piece or ridge pole, then the wedge-shaped hut is achieved. One end of this can be filled in and the other left open as a doorway. The North American Indians' hut already mentioned is an enlarged pattern of this type.

The conical hut is built after the same fashion as the Tee-pee. A tripod of three poles is first erected, other poles are set up round it, and the framework is covered. Naturally the size of the structure desired and the kinds of material available will govern the construction. A small hut of this nature can be thatched or covered with turf, but in this case light branches will have to be woven or lashed across the poles forming the framework in order to afford a foundation for the thatch. A larger hut will usually require canvas or other manufactured material as a covering, since skins and buffalo robes are not readily available. The making of a Tee-pee is described in Thompson Seton's *Two Little Savages*.

Larger Huts

The erection of larger huts almost invariably necessitates the erection of walls

Hurdles can be built after the same fashion as the lean-to by lashing a framework together and thatching it with any available and suitable material. These hurdles can then be erected vertically and lashed together. Two large stout poles and one sufficiently long and strong to act as a ridge pole will be required for the roof which is built after the fashion of the wedge shelter. Triangular hurdles can be constructed to fill in the space above the end walls and the roof. It will be found necessary to sink the poles carrying the ridge pole well into the ground if the roof is to remain stable.

A more elaborate form of the same hut can be built by erecting a proper framework of corner posts, etc., first of all. In this way a stronger and more permanent structure can be erected, but it is not necessary to go into full details of construction, as these are fairly obvious, and it is much more fun working such things out as the building progresses. Frequently it will be found, however, that the trunks of adjacent trees will provide a framework, and that it is only necessary to connect them up with cross-pieces, in order to secure a really solid structure. Care should, however, be taken to protect any living trees from damage by placing strips of sacking under any lashings.

If a fair-sized project is being undertaken it is advisable to draw out rough-and-ready plans first of all as a general guide and to designate those who are responsible for the work and who are authorised to issue orders. Unless some general plan of action is decided on, the work may end in entire confusion. It would be as well, too, to work to some kind of programme in regard to time.

Kitchen Shelters

It is frequently desirable, if not necessary, to erect some kind of shelter over the kitchen fire in camp in order to keep off the rain. A mistake is frequently made in having such a shelter too low, so that the cook's back is doubly bent with his burdens. The shelter should be high over the fire itself but should slope steeply into the wind and rain, so as to afford the maximum amount of protection; a wall on the weather side will usually be an advantage.

The first consideration is the material available for the roof. If there are old groundsheets or a tarpaulin handy, these are the best to use, although they may not be very romantic. If a

shelter of some permanency is desired, or if such coverings are not available, then some kind of a thatched roof will have to be built. A hurdle should be made and thatched so as to render it as waterproof as possible. Four, or more, uprights will then be required. These should be let into the ground, lashed

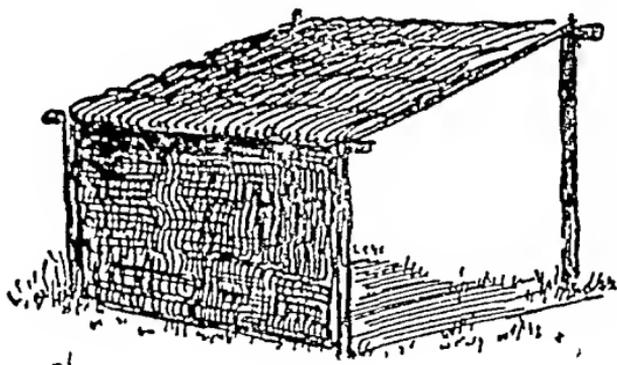

Fig 60

together with poles across the top, and, if necessary, guyed. Cross pieces may be added if necessary, and the hurdle laid on these and lashed firmly to them. Fig 60 shows a kitchen shelter to which a weather wall has been added.

Dining Shelters

Dining shelters can also be constructed on the same principle, or more elaborate structures can be built if time and opportunity afford. The simplest shelter is just a tarpaulin or waterproof

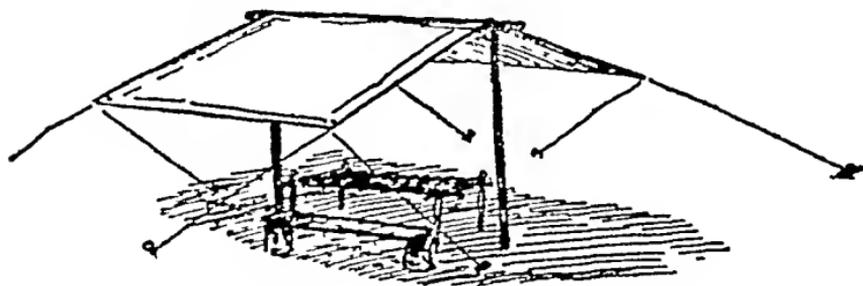

Fig 61

sheet slung over a central cross-piece and guyed out at the corners (Fig 61).

A more elaborate shelter can be built with six uprights after the style of a hut without walls. Two of the uprights hold the ridge pole, and the others the eaves of the roof. The roof can be made of canvas, or be boarded, shingled or thatched. If boards are laid to form the roof, they should overlap further

than appears necessary in order to allow for drying and consequent shrinkage or warping. Shingles are thin pieces of wood used as a roof covering in the same way as slates. They are usually split from cedar or oak, by continually halving segments of a log until the requisite thinness is obtained. In some countries it is possible to use slabs of bark in order to cover a roof.

If shelters of this kind are to be of a permanent nature, it may be advisable to fill in the side from which the wind usually comes, so as to give more protection.

General Interest.

It has not been possible to go into details in regard to the building of shelters and huts, for, as Dan Beard has shown us, the subject requires a whole book to itself. Certain varied types have been suggested in the hope that those Scouts and Rover Scouts who are interested may utilise these as examples, and may make further developments on their own. Half the fun of this kind of pioneering lies in the finding out of things for one's self. All of us in our young days remember the resentment almost with which we received the kindly-meant advice of our elders in regard to any hut or other erection that we were building on our own. What the Scouter should try and do is to encourage this kind of activity by yarns and occasional demonstration. Therefore, he has to try and provide the opportunity for the Scouts to get on with the doing of things in camp or otherwise, both so far as place and materials are concerned. There is occupation here for camps of all kinds, afternoons in the open air and so on, and it is real Scouting.

CHAPTER XIII

DISPLAYS AND RALLIES

"These displays are very popular both with performers and with the audience" (*Scouting for Boys*)

DISPLAYS and Rallies are useful as affording Scouts opportunities of demonstrating to others the kinds of things that they do in their normal Scout training. They are also useful from the point of view of training since practice and skill are required if the display is to be a success. Even the comic element which should generally be introduced into a display in order to afford relief and keep the audience amused, has its value in training. It takes a deal of hard practice and a considerable amount of skill to act the clown successfully.

PIONEERING

Quick Results

However, now we are concerned with pioneering, and with ways and means of demonstrating that activity in Scouting to others at a Rally. In the beginning we are faced with a great difficulty. Anything done at a display or a rally must be rapidly executed if it is to meet with success. An audience soon gets bored watching the bent backs of boys who are engaged in lashing, say, a trestle. Like the Wolf Cub, the public expects to see quick results and it is up to us to produce them on these occasions. This usually means that a certain amount of the spade work must be done beforehand, but it means more than that, it means that all those engaged on the job must be drilled well beforehand so that each knows exactly what his part is and is able to do it in the shortest possible space of time.

It amounts to this, therefore, that although speed should not enter into real pioneering to the detriment of the work done, since the security of lashings is of much more importance than the speed with which they are made, yet speed must be an essential part of pioneering displays.

As has been suggested, this can be overcome in part by previous preparations. For instance, if a bridge is being set up, it would be quite in order to bring on trestles already lashed, and to limit the display to the setting of them up and the lashing of a footway and handrail so as to form the bridge. Similarly everything can be rehearsed and marked out beforehand so that the Scouts know exactly where each lashing is to come.

Real Practices

The public generally likes to see something spectacular, and will not be put off with a dummy. If a bridge is built, or a tower erected, their utility as such should be demonstrated at the end. This is the climax of the display, and, thereafter, the structures built should be cleared away as rapidly as possible without a thought to anything but rapid demolition, or left as set pieces which will not interfere with, and even possibly aid, subsequent scenes. The main point is that when the job is completed and shown to work, that should be the end of it.

As an offset to this question of speed, however, it has to be remembered that our public really does want to see those activities in which Scouts normally indulge, and not something just got up for the purpose of a theatrical display, and for no other reason. Besides, it is more than likely that there will be in the audience some who, by reason of having been Scouts themselves or otherwise, will have a certain amount of know-

ledge as to how things should be done, and will spot shoddy and skimped work

So it is that if displays and rallies interfere with the normal Scout training of a Troop, they are apt to hinder 'instead of assist the development of the boys which must always be a prior consideration

Indoor Displays

Pioneering displays indoors are naturally limited by the solid nature of the ground and by space. There are, however, one or two practices that can be demonstrated indoors. The tripod flagstaff (p 69) can be set up indoors, on a stage or on the floor of a hall, and if the tripod is lashed beforehand, this can be done very quickly as part and parcel of a camp scene. The light pole

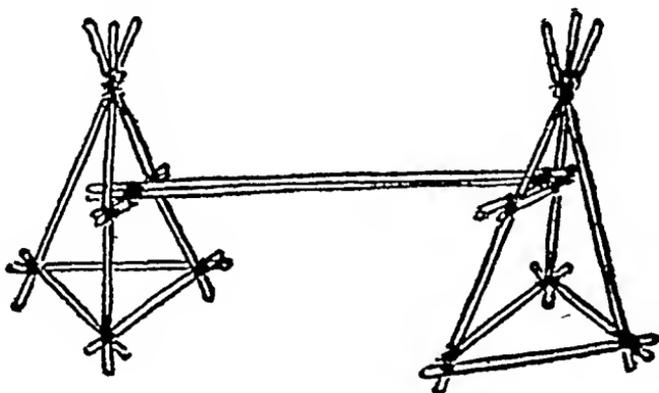

Fig 62

bridge (p 57) built with Scout staffs has also been used successfully indoors; hooks screwed into the floor or wall can be used to anchor the ends of the bridge. Here, again, if the sheer-legs are lashed beforehand a good deal of time will be saved.

A three-legged trestle bridge is quite suitable for display purpose, although of not very great practical utility as compared with other types of bridges. Three Scout staffs are lashed together to form a tripod in the usual way. Ledgers are lashed near the butts, or the legs kept in position in an equilateral triangle by lashings. A transom is lashed across two of the legs at the required height above the ground. Two of these trestles form one pier of the bridge, a couple of staffs being lashed to the two transoms to connect the two together (see Fig 62). The bridge is formed of a succession of piers, the roadway being laid across the staffs joining the three-legged trestles together.

The previous preparation of these tripods will obviously effect a very great saving of time

This type of bridge has been found effective on marshy ground

Use can also be made of four-legged trestles, which are built in the same way as trestles for the single-lock bridge (p 66), the two trestles being connected by short ties near the butts on each side, so as to be able to stand rigid on their own legs. In this way, a bridge, platform or signalling post can be built. Accurate marking out and lashing are essential if the trestles are to set square

Camp shelters of various kinds can also be built and set up indoors, using blankets, groundsheets, etc., as covering materials. In most cases it will be found advantageous to lash staffs or poles close to and inside the butts of sheer-legs, tripods and so on so that the weight of the structure is borne by these staffs and not the butts of the legs only. This will make for stability on a smooth floor

Outdoor Rallies

Out of doors there is obviously much more scope for pioneering displays. Practically all the practices suggested in the previous chapters can be incorporated into a rally, once the vital elements of time and results have been realised to the full

Bridges, towers, shelters and everything else can either be erected as part of the displays, or built beforehand as side shows. Rides on an aerial runway suspended from a tree down to the ground have proved a source of much profit to more than one Troop at money-raising displays

The monkey bridge with rope handrails and roadway, held apart by staffs (p 53), can be adapted to display purposes

If only light ropes are used, lariats or 1-inch rope will do if in good order, the handrails and roadway are attached to the staffs by clove hitches, so that it is only necessary to lash the sheer-legs. Some kind of rope tackle can be used to tighten up the bridge when it is erected as suggested in the illustration in Fig 63. This monkey bridge can be erected in a very short space of time if all the ropes are marked previously where the clove hitches come and a good deal of drilling and practice is done beforehand. The distance between handrails and roadway and between the staffs holding the ropes apart should be 2 feet 6 inches in both cases

Competitions for Displays

Whatever may be the value of competitions otherwise, there is no doubt that it adds to the interest of a display if

two or more teams or Patrols are competing against each other

There are various pioneering practices that can be adapted to competitions, always bearing in mind that for real pioneering safety and security are of more importance than speed

Several of the practices already mentioned can be so adapted Another very exciting and amusing one, although of small practical value, is the flagstaff race The object of each Patrol is to erect as tall a flagstaff as possible, using Scout staffs and sisal only The staffs are lashed end to end, and a set of three guy-lines is allowed to every three staffs, and a time limit of

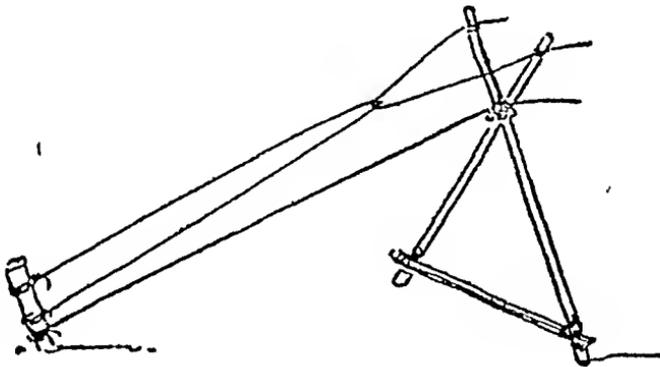

Fig 63

10 or 15 minutes is set If lashings are at all loose, the staffs will quickly swing from the vertical, bend and collapse If an equal strain is not maintained on the guys, the same disaster will happen Teams of six or eight are quite sufficient for this event

Other competitions in the shape of obstacle races will also prove "popular both with performers and with the audience" A course can be set during which ditches, walls, rivers and other difficulties have to be overcome by utilising any material that may be carried or found lying about If sufficient space and material is available, it is best to have two teams at least competing against each other at the same time, otherwise the competition will have to be mostly on a time basis which is not nearly so exciting

The dismantling and transporting of trek-carts over a wall is an example of this kind of a competition, although as a rule it does not prove very good for the trek-carts The Tournament at Olympia furnishes us with a competition of this kind to try and emulate, and gives us an example of the speed that can be obtained through constant practice

Practice for Displays

As has been already pointed out, however, displays should not be allowed to interfere with the normal Scout training of a Troop, but should merely act as an incentive to get on with some Scout activity or other which will be of real value in the training of the boys. The formation of special teams for display purposes should be avoided, and, so far as possible, the normal Patrols should be preserved. In the more elaborate pioneering displays it is possible for the whole Troop to be occupied if a proper division of the jobs is made, and some part of the whole allocated to each Patrol. Two or three special practices will of course be necessary, but they are more generally useful as instilling discipline and smartness, both of which should be common Scout qualities, but which are too frequently absent from some Scout Troops. Despite all this practice, the fun of the thing should not be lost sight of. It is the spirit that counts, and provided a Patrol or Troop tackles one of these more ambitious displays cheerfully, and to the best of its ability, mistakes and small failures do not so much matter. All of us, whether Scouts or not, would sooner see that, and enjoy it more, than watch a well-drilled Troop going through with a similar kind of job like a machine, and without a smile or other sign of humanity.

The point to remember always is that we are not out to be expert pioneers, we are out to use pioneering to make us expert Scouts, and there is a great difference between the two.

CHAPTER XIV

INSTRUCTIONAL MODELS

“If you do not know enough about it yourself, get a friend to come and demonstrate with models or instruments for a few evenings”
(*Scouting for Boys*)

MENTION has already been made from time to time of the need for preparation and training before putting actual pioneering practices into effect in the open. Scouting is eminently a matter of the out-of-doors, and the only reason why we do any of it indoors is that the weather will not permit us to go out. This, however, need not hinder, but help, our outdoor Scouting, since by our indoor preparations and practice we should be in a position to get right on with a job, knowing what is required and what we have to do, as soon as we do get out of doors.

INSTRUCTIONAL MODELS

Too often, however, our indoor Scouting does not prepare us for the real thing, but is just a kind of parlour-scouting as far divorced from the real thing as table football is from the real game.

Pioneering is hand work, and as such is the natural extension of the making of plans and models. So it is that the making of models indoors, when he cannot get out, can be almost of the same value to the pioneer as the making of plans is to the builder. Model bridges, say, of various types are full of interest to everybody, and demonstrate the uses of lashings, knots and hitches in a very practical manner. The interest that boys (and their fathers!) take in models is too well known to need more than a passing mention.

Models can be instructional from the point of view of what is learnt in the making of them and of their subsequent use for purposes of demonstration. From the latter point of view it is generally best that models of such things as bridges should be left partially finished so as to show the process of construction clearly.

Knotting Boards

First of all mention may be made of the value of knotting boards to show the various stages of the construction of different knots, whippings, splicings and lashings. The value of these has been underestimated in the past, with the result that if a Scout Troop has a knotting board at all, it is content with one which a keen and expert knotter has made. There is no reason why such boards should not be made for each Patrol as part of an inter-Patrol competition, while it is still more valuable if every Scout in the Troop is required to produce one. A minimum standard of knots to be done should be laid down, but all and sundry should be encouraged to add to that minimum as much as they can. It is rather difficult to imagine a maximum, but perhaps it might be attained by some 150 different knots, hitches, bends, whippings, splicings and lashings. Anyway an average Scout and an average Troop would probably be quite content with that!

Materials for Models

For the making of models of bridges, fireplaces, camp-sites, shelters, log cabins, and so on, the following tools and materials will usually be required.

Tools : A good sharp knife, hammer, punch, pliers, bradawl, screwdriver, paint brushes, small pair of forceps.

Materials Modelling clay, "Seccotine" fixative (3d, 6d, ..

or 9d per tube), water-colours—student's quality (2d in small china pans), oil colours—"Crusoe" brand (small tins 2d each), builder's chalk lines (3d each), fishing line, fine sand, fine gravel, small stones, household pins, oval brads, panel pins, countersunk screws

For base and woodwork

Three-ply wood in sheets, cuttings off joists and spars (from builder's yard), pieces of birch or alder, cuttings from black-thorn or hawthorn (the portions with natural bark very carefully dried)

For trees and bushes

Pieces of sponge, soaked in green water-colour of various shades, thoroughly dried, and *torn* up to the required sizes

For working parts

Single and double sheave blocks, snatch blocks, etc These should have brass sheaves and be stopped with brass wire, and can be procured from Steven's Model Dockyard, 112 Beresford Road, Green Lanes, London, N 8, Gamages, Ltd, High Holborn, London, Meccano, Ltd, Old Swan, Liverpool, etc etc

Selecting the Scale

The scale is a very important part in a model, where accuracy is a matter of some moment. The most satisfactory scale to adopt for practically every type of model is 1 inch to a foot. This scale is small enough to enable models to be made of quite large objects, such as log cabins and long bridges, and yet large enough to enable a great deal of detail to be shown correctly. Smaller scales require boot, or carpet, thread for lashings, and are too small to show knots, hitches and lashings, although they may serve to demonstrate the various types of bridges, say, in use. If all the details of the model are true to scale, material, texture and colour, then the model makes itself

Making the Base

Whatever type of model is being made, its basic framework should always be strong enough to stand handling and lifting by one end, without the construction being disturbed in any way. The framework, therefore, should be made of deep section, and be well nailed, or preferably screwed, together. The area of the framework will naturally be dependent on the size of the model to be constructed, and should not be skimped in any way (Fig 64). A sheet of 3-ply wood is then cut to the necessary size, about a quarter of an inch less all

round than the framework, and is screwed down on the framework from the top. Blocks of wood should be glued to the

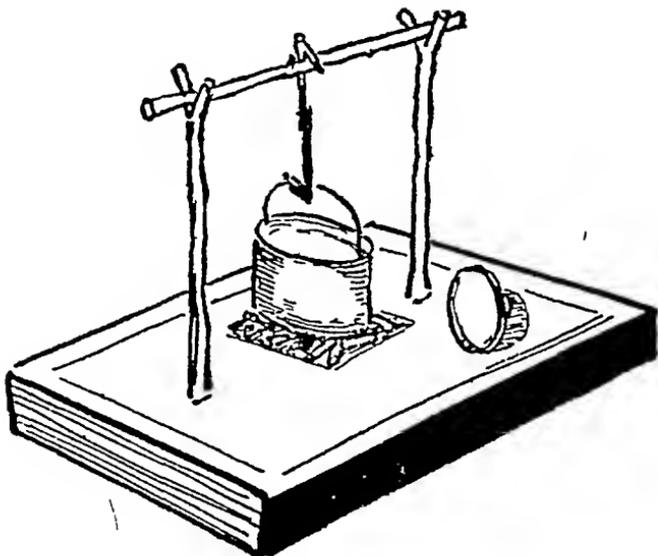

Fig 64

underside where depth is necessary for boring holes to fix main uprights, butts of trestles, and so on

The Banks of a River

The usual form of bridge model represents the section of the river to be bridged. A very useful and interesting model,

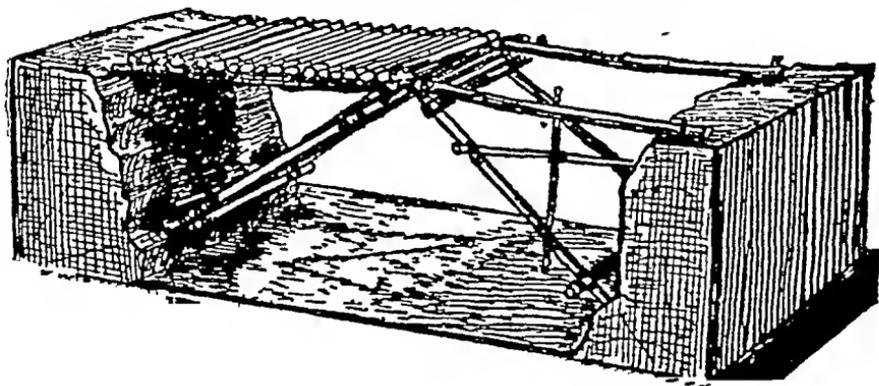

Fig 65

if a trifle unwieldy, can, however, be made to show a number of different types of bridges spanning the same stream.

In order to make the banks, blocks of wood of the same width as the base should be firmly secured by screws from the underside of the plywood. These should be roughly shaped so as to show variations in the conformation of the land, and to give character to the bank faces (Fig 65)

Laying the Ground Surface

The surface of the base, and of any blocks screwed to it, should then be covered with plastic modelling clay. Reeve's "Duroplast" Modelling Paste is excellent for the purpose and costs 9d a tin. One tin can cover about 600 square inches of surface. This mixture will adhere to wood, metal, china, stone, cardboard—in fact almost anything. It sets hard in a couple of days, but can be broken up and brought back to its original plastic consistency by adding water. There is no need to go into the details of its use, as they are to be found on every tin. Should some kind of an undulating surface be required, it will be necessary to affix rough pieces of wood, varying in size and thickness, till the general conformation desired is effected. In order to avoid cracks, however, it is best to cut and gouge one single block of wood. The whole can then be covered with the plastic clay and finished off to hide all the joints and sharp edges. This surface can be painted, and covered with sand, gravel, stones, bushes, etc., as desired.

In order to procure an imitation of rough ground, scotch-tine is applied to the required area, and then sprinkled freely with sand, or any other material used, so that the area is completely covered. When everything is hard and dry, the residue which has not adhered can easily be tipped off. Small stones should be set separately.

Colouring the Surface

The colouring of all grass surfaces should be rather more vivid than eventually required since the plastic clay is absorbent, and the colours will tone down as they get thoroughly dry. Oil colour of a bluish tint will be found most suitable for the rivers, as the glazed surface suggests wetness. If water-colour is used, a coat of clear varnish will give a similar effect.

Building the Model

The model itself should be built up bit by bit, in precisely the same way as a full-size job is tackled. Great care should be taken with measurements, so that all proportions are correct. This is especially necessary in the building of trestles. The correct knot and the correct lashing for the purpose

should always be used, and a pride should be taken in having everything correctly done in every detail

Where a lashing is applied to join two spars, the surface of the wood that the lashing is to cross should be slightly gummed so that in the event of the wood shrinking, as it invariably does, or of the cord becoming loosened, owing to changes of temperature, the strength of the join will not be impaired

So far as is possible all the members of the Patrol or of the Troop should be concerned in the building. Apart from the making of the base and the making of different parts of the model, the painting, and so on, which can all be given to different Scouts to do, there is the collection and preparing of the material. A certain number of sticks of different lengths are required, cord has to be cut to required lengths, the plastic clay has to be worked, colours have to be mixed, and so on. These are jobs which can be given to the Scouts who are not so proficient with their fingers as others

It is a mistake to leave all the work to be done by one who is already keen on that sort of thing. Every effort should be made to get others interested, and the surest way to interest them is to give them a job connected with the work. Occasional inter-Patrol competitions in producing models in the making of which each single member of the Patrol has had a hand is a helpful way of giving practice and encouragement to all

Frequently it will be found that it is the odds and ends of little finishing touches that cause the most interest and joy. It is worth while, therefore, reproducing a few sentences from an article on "Model Making" that appeared in *The Scouter* for April 1930:

"The tent should be carefully cut out of stiff drawing paper and fixed on its poles, with guy ropes of fine string or thread to little pegs driven into the surface. The fire, formed of tiny twigs gummed to the 3-ply, can be made very real by the inclusion of a small piece of red tinfoil such as is used for the covering of fancy chocolates

Small bushes are best fashioned out of pieces of sponge stained green, and trees can be effectively built up on shapely twigs by the same means. Fence posts are easily made from match-sticks with rails from the thin wood of match-boxes. A pool or stream always looks very effective and is simply formed with a scrap of glass, coloured blue on the underside, and fixed flat, the plastic clay being carefully finished off to cover all edges."

It is in the embellishment of the model that scope lies for the exercise of ingenuity

Results

The actual results produced by Scouts will at first be crude, but practice will soon improve that. Apart, however, from what is actually learned in the building of models, a good deal is also learned about the actual thing. For instance, the model of a bridge obviously teaches the makers about the different knots and lashing that are required, the proportions that are necessary, and the way in which everything has to be set up. In the same way the model of a camp site will illustrate the position of tents, fires, latrines, and all the other many things that go to the building up of a good camp.

"Model-making does call for patience, care, deftness, originality, ingenuity, imagination, resource and observation—all good scouting qualities—and brings constructive and inventive faculties into play, the while providing a most absorbing hobby. Truth, correctness of detail, and imitation of reality—always with an eye to correct scale—will be rewarded by success."

And besides being good fun, it is all good indoor pioneering that any Troop, or Crew for that matter, can take up in the winter months.

CHAPTER XV

THE PIONEER'S TOOLS

"A Scout must know how to use an axe or billhook" (*Scouting for Boys*)

AN axe has an appeal to the normal boy and man, and at once conjures up visions of backwoodsmen and husky men. There are, however, other weapons that the pioneer needs if he is to do any job that comes his way. It is the pioneer that prepares the way, removes obstacles, makes a road, and gives an easier passage to those who follow, as well as doing the most spectacular work of throwing bridges across rivers and ravines. Scouts, and perhaps especially Rover Scouts, should be led to see that very frequently it is the ordinary cleaning-up jobs that render the greatest service to others. Rover Scouts can be of real help to Scouting by undertaking the clearing and maintenance of Association, District and County camp sites, and many crews have done excellent pioneer work in this respect. The keeping clear of rights-of-way has already been alluded to, and there are other similar pioneering jobs that will give help to the general public as well as to Scouting, not only in the depths of the country, but near-by towns as well.

When general clearing-up jobs are taken up on public land or in grounds belonging to institutions and hospitals those responsible must make certain first of all that they are not depriving anyone else of a chance of employment. Great care has to be exercised in this respect as there have been occasions when Scouts have been used just to save money, and it is not right that Scouting should be exploited by unscrupulous people.

Apart from axes, rope, blocks and tackle, and timber, the pioneer also needs such unromantic tools as spades, shovels, picks, mallets, mauls and saws, and it would be as well to say a word about these, too.

Spades, Shovels and Picks

It is not necessary to describe a pick, a shovel, or a spade, nor is it necessary to give much in the way of advice as to their purchase. Such things can be picked up anywhere fairly cheaply. There is still a certain amount of surplus supplies available where picks and shovels of sound make can be obtained at reduced rates. It is a mistake to put off with toys, it is the real, genuine article that the pioneer needs. They are required for clearing the ground, levelling it up, cutting ditches to run off water, as well as for digging anchorages and holes for footrests in building, and for the construction of latrines, grease pits, refuse pits and incinerators in camp. A pick and a couple of shovels should be included in the equipment of any Troop that goes to camp, whether it is going to indulge in pioneering practices or not.

Scouts should be trained in their use beforehand, so that they can get on with a job without wasting unnecessary effort. It is mostly a matter of swing, rather than of force and lift, and the art of wielding a pick or shovel can be easily acquired by watching someone who knows how to do the job.

These tools should be taken care of, always cleaned up after use, and the handles oiled from time to time to keep them from getting brittle. When being laid away for the winter, the heads of all shovels and picks should be greased to keep them from rusting, and it is generally best to wrap them up in a piece of old sacking.

Mallets and Mauls

Mallets are always necessary for knocking in tent pegs, but they are required in the pioneer's equipment also for knocking in small pickets for guy lines, and in order to help to strain lashings, mention of this has already been made on p 20. Sometimes instead of an ordinary mallet, a special mallet called

a frapping mallet is used to knock the coils of a lashing in together. Home-made mallets are best for this purpose (Fig 66)

A maul, as has been explained in the glossary, is a heavy wooden hammer used for the purpose of knocking in pickets, especially those used for anchorages. Some practice in swinging is required as otherwise considerable damage can be done to it and to the pickets, and sometimes to bystanders. The person wielding a maul should be particularly careful to see that there is no one else standing anywhere near. Care has to be taken about this when a 3-2-1 anchorage is being made, as very frequently when the maul is in action someone else is lashing the pickets together. The lashing should not be started until all the pickets have been knocked in. The timing of a stroke with the maul is frequently of more importance than the brute force exerted. A small patch of ground will give sufficient space for practice, and individual competitions will help to give Scouts more skill as well as a considerable amount of exercise.



Fig 66

Mallets and mauls should not be allowed to lie about in the wet more than is absolutely necessary and are best hung up when being stored away.

Saws

As a general rule there is not much need for saws in the normal equipment of a Scout Group, yet they are handy articles of the camper and the pioneer. For instance, a hand saw can be used for cutting firewood into lengths, and for a deal of the firewood used in camp makes a quicker and less wasteful job of it than an axe. A hand saw is not, therefore, to be despised. It is the push of the hand that cuts the wood, whereas in the cross-cut saw worked by two people it is the pull that counts. Just as a hand saw is sometimes preferable to a hand axe so a cross-cut saw is on many occasions a better tool than a felling axe for logging up wood and even taking down a tree.

Good hand saws can be obtained at a cost of from 7s to 16s, dependent on size and quality, cheap cross-cuts at from 8s 3d to 12s 9d, and better quality and more workmanlike cross-cuts from 14s.

Great care should be taken of saws to see that they are properly cleaned and dried after use and are oiled from time to time. When put away they should invariably be greased, wrapped in sacking, and laid flat on a shelf or hung up vertically.

The sharpening of saws is a difficult job, as each tooth has to be filed separately

Knives

Little need be said about these, except that if they are to be of any use at all they must be kept sharp. Knives are needed by the pioneer to cut cords and lashings, wedges, and for various other purposes. The Scout clasp knife with a marline-spike is of much more use to the pioneer than the sheath knife which is the tool of the hunter. Like every other tool a knife should be cleaned and the blade dried after use, the addition of a little oil occasionally is also advisable. There should be in each Group some kind of a stone, carborundum or other, that can be used by the members of the Group to sharpen any knives they may possess.

Billhooks

As the Chief Scout indicated in *Scouting for Boys* a billhook is a substitute for a hand axe. It is a very effective tool for chopping up wood, trimming light branches off trees, cleaning up hedges and so on. Those who are accustomed to a hand axe only will find it a somewhat clumsy tool at first until they have become accustomed to it. It is used more or less after the manner of a hand axe, but can be more easily controlled, and so is safer to handle. Despite this, however, the same safety rules apply, and should be scrupulously observed.

Billhooks suitable to our purposes cost from 3s 6d to 4s. 6d, and can be procured from most shops that deal in agricultural implements.

Types of Axes

The axe is the tool of both the pioneer and the woodman, and also of the fireman and the linesman. The axe that the last two use is for the purposes of breaking in windows, cutting away wire and of helping them to climb, and is not, therefore, the type to be used by the pioneer or woodman. This type of axe (Fig 67) should be avoided by the Scout since it is not suitable for his purposes.

Other types of axes are the chopper, the hand axe, the single-bitted felling axe, and the double-bitted axe. A chopper, or hatchet, is useful in camp for chopping up firewood, but its usefulness is limited by the fact that it is not a good tool for the accurate cutting of wood. A good chopper costs 2s 6d., and a good hand axe 4s, and the latter is better value for the money because of its added usefulness.

The ordinary or single-bitted felling axes are the ones that

should be selected for Scouts and Rover Scouts, the double-bitted axe being reserved for experts only. Felling axes can be obtained of different sizes and weights, and should be selected to suit those who are going to use them.

Rover Scouts can use a 4-lb full-size axe, which will cost about 8s 6d, a 3-lb axe costs 7s.

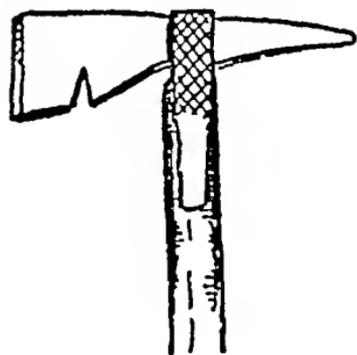

Fig 67

Three-quarter-size felling axes with a head weighing $2\frac{1}{2}$ lb are suitable for the average-sized Scout, and can be obtained for 5s 6d. Half-size felling axes with a 2-lb head are also available at a cost of 5s 9d and are quite good tools for younger Scouts.

It is a great mistake to attempt to wield an axe that is too large or too heavy. That is the cause of a number of accidents, since in such circumstances the axe is not under proper control.

It would seem advisable, therefore, that if a Scout Group is taking up pioneering or woodmanship it should lay in a stock of axes of different weights and sizes so as to suit the different ages and strengths of its Rover Scouts and Scouts.

The Care of an Axe

First of all care must be exercised in the choice of an axe to see that the head is of good steel, and the haft is sound. What is known as the Canadian dog-legged haft is most suitable, the wood used being ash or hickory. The head should be firm on the haft, the wedge solid and of one piece, and the axe true, that is the edge of the blade should be in the same straight line as the centre of the haft. It is best to get axes from the Scout Shop or from reliable makers rather than trust to luck locally.

The edge of the axe is sharpened by grinding it on a grindstone. Normally this is not done before an axe is sold, but the makers will do it if asked. Thereafter, unless the axe has been abused, it should not need more than an occasional touching up with a piece of carborundum stone, which is worked over the cutting edge with a circular motion. If the edge has been nicked a flat file will have to be used, working from front to back, in order to take out the nick.

The head should be carefully dried after use, and oiled occasionally. The haft, too, should be oiled from time to

time—any sweet oil, such as linseed, will do—to keep it from getting dry and brittle

When an axe is being laid away, the haft should be oiled, and the head greased and wrapped in sacking. It will then be ready for use at any moment after the oil and grease have been wiped off.

One of the most frequent dangers to guard against is the head of an axe working loose on the haft. This can be temporarily remedied by hammering on the end of the haft so as to jump the head back up it into position, and then by immersing the head in a bucket of water, or preferably oil, so that the end of the haft may swell up and fit the socket in the head. But, as the haft dries again, the head will work looser than ever. To make a complete job of it it is necessary to re-wedge the axe. A new wedge should be cut out of some hard wood like oak. This should be dried thoroughly by baking in an oven. The head is then worked off the haft, the old wedge removed, and the haft refitted so that it fills the socket completely. The new wedge is then inserted from the top and hammered well home. It is helpful if the tip of the wedge and the end of the haft are dipped in linseed oil immediately before the head is put on, as this acts as a kind of cement and holds the two more tightly together.

Any trouble expended in the care of an axe will be well repaid by the time it will then last. Unless an axe has been very badly handled it is hardly ever necessary to replace it. Hafts sometimes break, but spare hafts can always be obtained and inserted in the old head.

CHAPTER XVI

USING AN AXE

“Never play the fool with an axe, it is a dangerous weapon”
(*Scouting for Boys*)

APART from normal pioneering purposes, it seems desirable to lay special stress on how to use an axe, since the building of log cabins is discussed in the next chapter. The fact that an axe is the normal tool of any Scout who goes to camp does not seem to be sufficient for many Scouters to realise that each and every Scout should be told the safety rules for axemanship and shown how to use an axe beforehand. A hand axe is quite as dangerous a weapon as a felling axe, and because it is in more constant use should be treated with more respect than it normally gets.

Safety Rules

There are certain well-known safety rules which apply to the handling of an axe, whatever its nature and use, just as there are certain others which apply to a felling axe and its use in felling a tree only. It would be as well to give both sets now, so that our list of safety rules is complete.

Mask an axe when not in use

When an axe is being carried, it is best to have a special mask or case for it so that the cutting edge is covered. When an axe is being laid aside after a job of work has been completed, the edge should be masked, either by placing it in its case, or by jabbing it into a log or stout branch. As much of the haft as possible should be covered by the log, in addition to the whole of the cutting edge being imbedded in it.

Never chop leaning sticks

When chopping firewood, or cutting a pole to a required length, always rest the part of the stick to be cut on a solid surface. If the stick is leant up against a log, and struck in the middle the ends are almost bound to fly into the air, and may do damage. In cutting small branches for firewood it is always best to hold them in the left hand and lay them across the chopping-block, resting the place to be cut on the far edge of the block, so that the blow with the axe can be directed down and away.

See that everyone is a good distance away from the axe

This safety rule seems so obvious that it should not be needed, for common sense is the golden rule of axemanship as well as of life in general, but experience shows that it is the rule most frequently disregarded. It applies to a hand axe just as much as to a felling axe. As applied to the felling axe, it is usually worded "onlookers must stay two axe lengths away."

The remaining rules apply mainly to felling axes and to their use when felling a tree, but should be applied wherever possible.

Carry the axe in a safe way

A felling axe should be carried either on the shoulder with the cutting edge facing out, or with the head held in the hand, cutting edge in, the hand and arm being at the side. The latter is the method adopted in lumber camps and is the safer of the two, although it does not look it.

*Companions must walk on the off side**Clear the ground an axe length around*

An axe length is really the circle covered by the axe when swung at full arm's length from the shoulder. All branches

and other obstacles within this radius should be removed, as if they are struck they are likely to deflect the blow

Stand on firm ground

Make sure that your feet are firm before beginning to swing an axe, as it is very easy to lose balance. It is better to stand square on to your job, too close rather than too far. When Scouts are using a felling axe at first it is best to put some kind of a fender in front of their shins to protect them. A form upset on edge affords good protection.

Rest when tired and mask the axe in a convenient log

When felling a tree, shout out to warn anyone nearby as it begins to move

Before making the final cuts, however, it is best to stop axing and look round to see that no one is too near. As the tree falls, shout "timber" or some other warning, and step to the side and watch the direction of the fall.

When a tree has been felled, see that the trunk will not roll before allowing anyone to approach it

When the tree falls it may rest on a branch or limb, and when this breaks, or is cut, the trunk may roll over. It is important that such a branch should be cut at once, if possible, so that the trunk may rest stable for the rest of the trimming-up operations.

Finally, so far as the safety rules are concerned, it is essential to remember to exercise common sense.

How to Use an Axe

When using a hand axe the blow should not be delivered straight down at right angles to the stick, but at an angle of some 45° to it. Small branches can be cut through at one blow, larger ones will need several cuts, alternately right and left, making a V-shaped cut. As mentioned, the branch should be laid across the far edge of the chopping-block, and all blows directed downwards. In splitting, it is best to lay the branch flat on the block, steadying it with the left hand, and to work gradually from the far end towards one. When pointing a branch, rest the end to be pointed on the block, and direct all blows down. (A good tip where a number of pickets or stakes have to be sharpened, is to burn the ends in a good fire so that they are charred evenly all round. The removal of the charcoal portion leaves a fine pointed stake, with a preserved surface.)

When using a hand axe to lop off small branches, the cut must be made from the underside with the grain.

The proper way to use a felling axe is to place the left hand

PIONEERING

on the "grip," when working right-handed, and the right hand on the shoulder of the haft just behind the head. The axe is then raised so that the head is above the right shoulder, feet apart, but square with the job. The axe is then brought down on the log at an angle of about 45° , the right hand at the same time moving down the haft towards the left hand. In this way the right hand throws the axe and the left hand guides it. After the cut the right hand slides up again to the first position as the axe is again raised. When working left-handed the position of the hands is reversed and the axe is raised above the left shoulder. In order to make a back-handed cut, that is a cut from the left when working right-handed, the axe is raised above the right shoulder, but as it is brought down the left knee is bent in slightly, the right hand thrown over to the left, and the left hand thrown over to the right, so as to change the angle of the blow from one of 45° to one of 135° .

The head should be kept down, and the eyes on the cut all the time one is working. There is no use in slogging with an axe, all the blows should be easy, so as to let the weight of the axe do its own work. The width of a cut at the surface of the log should equal the final depth of the cut, or "kerf" as it is technically called.

This short description of how to use an axe, covers all normal practice. Where so much depends on correct teaching by means of demonstration it would be a mistake to enter into more complicated details in regard to the handling of an axe for special purposes. It is absolutely essential that the woodman should be taught by demonstration and practice and not by theory, and so it is not intended to go any further with the theory of axemanship.

Materials to Cut

Something might, however, be said in regard to the materials to be cut for different camping and pioneering purposes.

First of all it is important that all hedges should be left undisturbed. On no account should dead wood for fires, or sticks for gadgets be taken from a hedge. It is in this way that gaps are made and that Scouts get into bad repute with farmers.

For firewood we would naturally select dead wood mostly, dead branches off a tree, fallen logs, and so on. The Scout also requires to have some knowledge of the right kind of woods to select for burning, but that is another story.

For the smaller gadgets in camp we should select green sticks from overcrowded thickets, where removal will benefit the remaining growth by giving it more air and light. For

preference we should select the crooked and weaker shoots, and not the strong straight ones which should be allowed to grow. In passing it may be remarked that the making of gadgets is in itself a pioneering practice, and good practice in lashing. As B-P. has written, "An item of pioneering might include camp fireplaces, ovens, latrines, soak pits, duckwalks, corduroy roads, etc." It is easy to see that we have by no means exhausted the possibilities of the subject!

If permission has been obtained to cut stronger and longer poles for various pioneering practices, careful selection should be made so that only those in overcrowded places are removed. Usually it is best to ask the owner of the thicket or wood to indicate what exactly can be removed. Quite a lot of useful material can, however, be gathered from saplings growing from the roots of trees, and from broken and hanging limbs. The branches cut will require trimming which should be done with the grain from the butt upwards, all the brushwood being carefully piled and destroyed. Whenever any branches are removed from a living tree the cut should always be made clean and subsequently treated with tar, or covered with clay so as to prevent decay.

As before, all hedgerows should be left severely alone.

CHAPTER XVII

BUILDING A LOG CABIN

"By the term 'Scouting' is meant the work and attributes of backwoodsmen, explorers and frontiersmen" (*Scouting for Boys*)

It appears that more Scout Groups than one would imagine are keen on building some kind of a Log Cabin, either as a Troop Headquarters, as a Crew Den, or as an addition to a permanent camp site. Rover Scout Crews have also combined together in order to erect Guest Houses for use by visiting Rover Scouts. It seems fitting, therefore, to conclude this book on pioneering with a description of how to build a log cabin, one of the most ambitious pioneering jobs that any Scout Group could undertake.

This description is the result of the practical experience that has been gained at Gilwell Park in building the Gidney Log Cabin as a memorial to the first Camp Chief. This cabin is possibly more elaborate than would be necessary normally, but by substituting other materials than those actually used at Gilwell the cost could be brought within the scope of an

PIONEERING

ordinary Scout Group. Such a cabin should of course be the work of the Group itself, so far as is possible. Expert advice and guidance may be needed in dealing with the chimney and the roof, but even so Scouts and Rover Scouts who have any skill with axe and tools should be able to do the bulk of the work. It will, however, be absolutely necessary to have a certain number of older and stronger fellows than the average Scout on the job, as logs are difficult to lift and handle.

Drawing up Plans

It is a mistake to make elaborate plans beforehand, as the materials used are not of uniform dimensions and, therefore, much of the work must be done by rule of thumb. Rough plans should show the approximate size to which it is hoped to work, the position of doors, windows and chimney, and the exact slope of the roof. From these plans it will be possible to make a rough estimate of the amount of timber required, though here again variations in the thicknesses of the logs make it impossible to arrive at an exact estimate beforehand. The best slope for the roof is about 4 inches in 1 foot, or 1 in 3. Wide-spreading eaves not only make the cabin more weather-proof, but add considerably to the picturesque appearance. A rough working plan of the Gidney Log Cabin and also the front elevation are shown in Fig 68. A verandah is not a necessity, but adds considerably to appearance and usefulness, and is well worth considering if funds will allow of the extra expense.

Materials

It is best to take the different materials required separately and consider each in turn.

(1) *Logs or timber*

The cost of making a log cabin is determined largely by the availability of timber in the locality. This must naturally vary for every district, so that it is quite impossible to suggest how much will have to be spent on buying logs. The logs for the Gidney Log Cabin had to be brought 80 miles and their cost, including transport, was only £30. Spruce is the most convenient kind of timber to obtain. Good straight trees with as little taper as possible are required. The trees must be felled in winter, and the bark peeled off in the spring. It is a mistake to leave the bark on as it only harbours damp, disease and grubs.

Varying lengths and thicknesses will be required. For instance, if the cabin is to have a porch or verandah, the upright

BUILDING A LOG CABIN

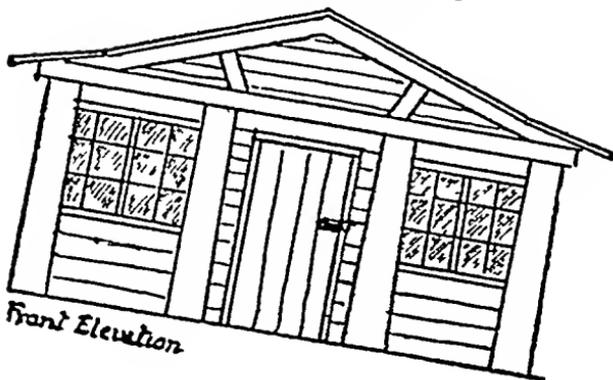
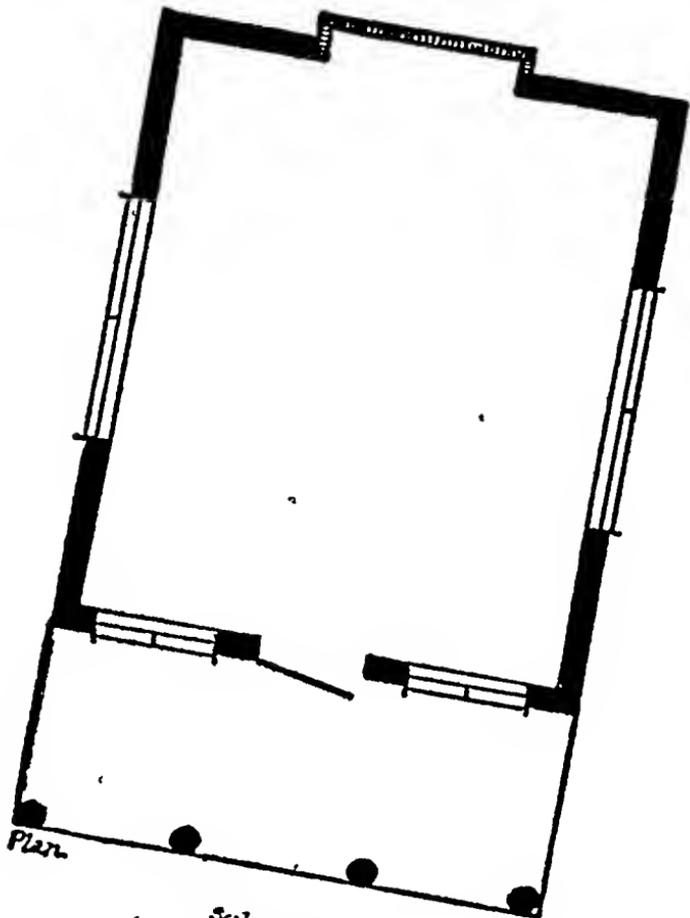

Fig 68

PIONEERING

supports must be of much stouter timber than wall logs, otherwise they will look weak. The longest lengths will be required for the tie-beams which must be very strong. Long lengths will also be needed for the purlins, and these must be thinner than the wall logs and, if possible, of uniform thickness. It is best to select the logs for the purlins first. The illustration at Fig 74 shows these different parts of the roof.

It is naturally better to get lengths of timber without any taper in them at all, but this is very difficult and would involve more expense and wastage. Convenient lengths for the end walls can probably be easily obtained. In the case of the side walls of a cabin of any size logs will probably have to be spliced together as described later. A convenient average diameter for the logs is about 9 inches.

(2) *Timber of windows, doors, etc*

It will probably be simpler to buy both the windows, which should be of the casement variety, and the door ready made up from a local builder, or to get them made up by a carpenter to one's own design. They should not be too well finished. The general appearance will be improved if the door and the window frames are worked over with an adze. If possible, old glass which is not too clear should be used in the windows, a bottle pane or two will add greatly to the appearance.

(3) *Foundations*

Cement, sand, gravel, stone and bricks will be required for the foundations and for the fireplace. For concrete use one part "cement" to four parts gravel, for cement use one part "cement" to three parts sand.

(4) *Roof*

The materials for the roof will be described in detail later on.

(5) *Spikes*

Spikes are required for fixing the logs together. These are best made about 9 inches long, from a $\frac{3}{8}$ -inch iron rod, and should be pointed at one end at a forge.

(6) *Tools*

The following tools will be required: hand axe, felling axe—for an expert a double-bitted axe is the most handy tool—adze, cross-cut saw, hand saw, hammer, sledge-hammer, mallet, large gouge, large chisel, brace and bit, square, spirit level, stone for sharpening tools. It depends on the number of people engaged on the job how many axes and such like will be required.

Laying the Foundations

If the logs are laid direct on the earth, they will very soon rot at the bottom, and the walls may subside. It is, therefore, essential to have some kind of foundation, however rough and ready, to prevent rot setting in. The best foundation is a solid platform of concrete, covering not only wall space but also floor space, and if the expense of this is too great, concrete foundations for the walls alone can be built. This foundation needs to be at least 18 inches deep and wide enough to project slightly on either side of the bottom logs. The surface of the foundations should be at the general ground level, unless it has been decided to have the floor of the cabin higher than that level.

Other forms of foundations can be made with slabs of stone, set at the corners and at intervals along the walls, brick piers would also serve the purpose. The whole structure can also be raised off the ground on brick piers at the corners or on heavy logs buried butt down, and projecting some 2 feet above ground, this is frequently done in Scandinavia. Whatever the form of the foundations, iron spikes should be let into the material while it is wet to take the first course of logs.

The Fireplace

As soon as the foundations are set, the fireplace should be built in position. The best fireplace is made from stone, but brick could be used, or brick faced with stone. The fireplace should look massive, and the chimney-stack must clear the ridge of the roof by at least 3 feet. The foundations of the fireplace must be deeper than those of the walls, and it is advisable to go down 3 feet for them.

The stone used is rough-hewn, set fairly wide apart and cemented together. The cement joints should be scraped out a bit so as to give a rougher appearance.

In constructing the actual fireplace it will be necessary to lay a curved iron bar across the top of the opening so as to support the chimney-piece (Fig. 69). This bar will take a certain amount of the thrust. The back of the fireplace itself must be of fire-bricks. A stout curb across the opening and a hearth of flat stones laid in front will lessen the risk of fire.

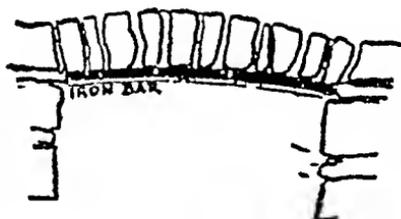

Fig 69

PIONEERING

A rough mantelshelf can be let into the chimney-piece while it is being built

Building the Walls

It is clearly necessary for the logs, which are laid horizontally one on top of another, to fit closely together in order to make the walls weatherproof. The first task, therefore, is to hew the logs so that each log has two perfectly straight faces about 2 or 3 inches wide. The hewing is done with an axe or an adze, both of which need very careful handling for this task.

The heaviest logs should be picked out for the bottoms of the walls. In the course of the hewing a straight edge must be used from time to time to make sure that the work is quite all right. When a few logs have been so prepared the first courses of the walls can be laid.

It is important to make sure that the bottom logs are so laid that the flooring will come right up to them, so that it is a good plan to set these first logs actually on a strip of the same kind of wood as will be used for the flooring.

Before any logs are laid, the door frame should be set up in position.

• It will probably be quite impossible to get logs long enough

for the side walls, so that two logs of the same diameter will have to be spliced together in one of the ways shown in Fig 70. This splicing is by no means such a simple matter as it looks, and a good deal of care and patience, and many trials, will be needed before an exact fitting joint is secured. The first method is much more satisfactory, but more difficult to execute.

The logs for the walls should be long enough to give a fair overlap at the corners, as this improves the general appearance of the cabin considerably. There are two main kinds of locking that can be used. The first method is known as the "saddle and notch". A good deal of skill is required to make a perfect joint, and it is advisable to have some preliminary practice on some odd pieces of timber in order to get a clear idea of what is required first of all. It makes for a quicker and more exact job if a saw is used to cut down through the centre of the notch to the necessary depth before axing it out. The second method is to leave the lower log untouched and to shape a semicircular joint in the upper log (Fig 71).

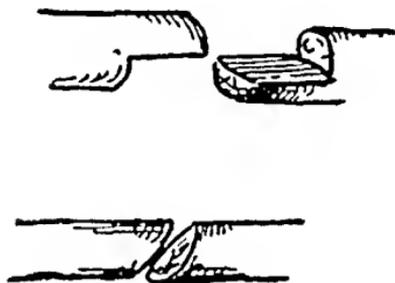

Fig 70

In this way all four walls should be built up to the level of the window-sills. On the side walls from now till the level

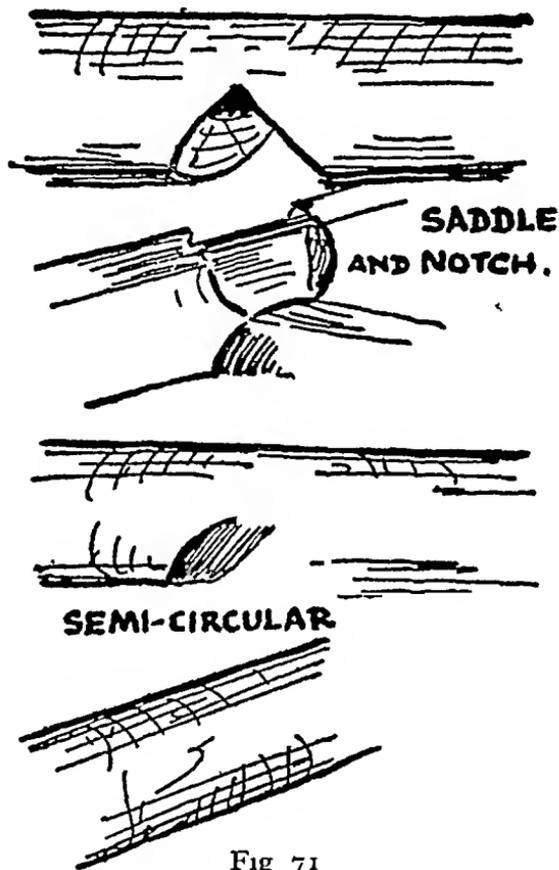

Fig 71

of the tops of the windows is reached, splicing will not be necessary, as the logs can be of any convenient lengths on

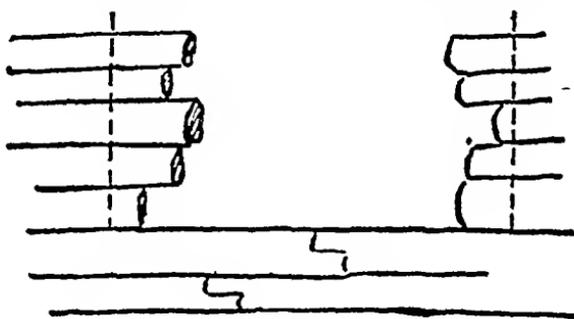

Fig 72

either side of the window, and the exact window space sawn out (Fig 72) after they are all in position, and the window

PIONEERING

frames built in In the Gidney Log Cabin the window frames were put in position as soon as the sill level was reached The logs had then to be fitted into the sides of the frames, this is more difficult than the cutting-out method suggested

On the fireplace end the logs must be fitted into the brick-work or stonework, in which a channel should have been left so that the ends of the logs are covered both outside and inside

As each log is laid it will be necessary to caulk and spike it There are various methods of caulking One is to use a mixture of putty and tow The tow should be chopped up fine and mixed with the putty The mixture is rolled in the hands into long strips and placed at one edge of the squared surface of the under log, a similar strip is placed at the other edge, and the top log placed in position Another method is to use moss which is not so durable There is a new composition on the market called "Rucel," a rubber mixture, which suffers from the disadvantage of being black, but which is very useful for recaulking Whatever material is used for caulking must be of such a nature as to remain in place when perfectly dry It will be found that as the logs dry out, a good deal of recaulking will be required, as a certain amount of shrinkage and movement is bound to occur which will leave chinks

The logs should be spiked together about every 4 feet It is best to drill a hole through the top log to prevent splitting, to insert the spike in the hole, and drive it well home through into the bottom log with a sledge-hammer

Starting the Roof

The roof is supported by two or three trusses according to the length of the cabin Each truss consists of a horizontal log, the tie-beam, which rests on the two side walls To this are bolted the rafters, which give the slope of the roof, and these in turn are strengthened with braces which are fastened between each rafter and the tie-beam (Fig 73) When the trusses are in position they are fixed together by purlins fastened on top of the rafters and running parallel with the ridge and the walls (Fig 74) As this is a difficult business, it is strongly advised that a small model of the roof structure should be first made

The trusses are made on the ground, and then placed in position as soon as the wall logs are level with the tops of the windows A great deal of care will have to be taken to make sure that the tops of the walls are level As the tie-beam is of some length, it is sure to taper to a certain extent, and therefore some adjustment may be necessary to keep the top

of the beam level. At this stage of the proceedings the spirit level should be in constant use.

Once the trusses are in position, the next course of logs has to be placed so that the line of their tops coincides with

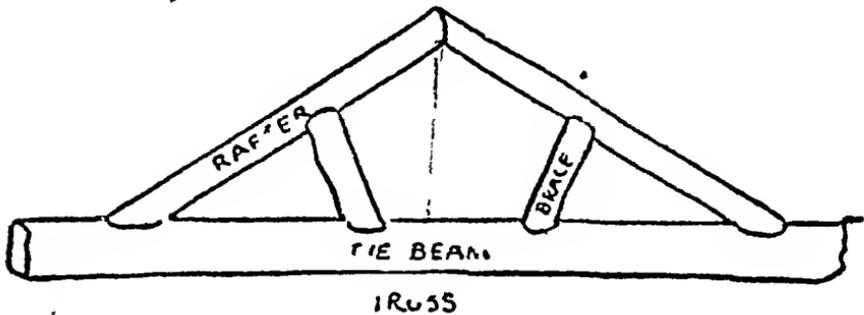

Fig 73

the level of the tie-beams. This course of logs will have to be chosen and hewn very carefully in order to maintain this level, and the ends of each should be given a semicircular concave joint to fit into the curve of the tie-beam.

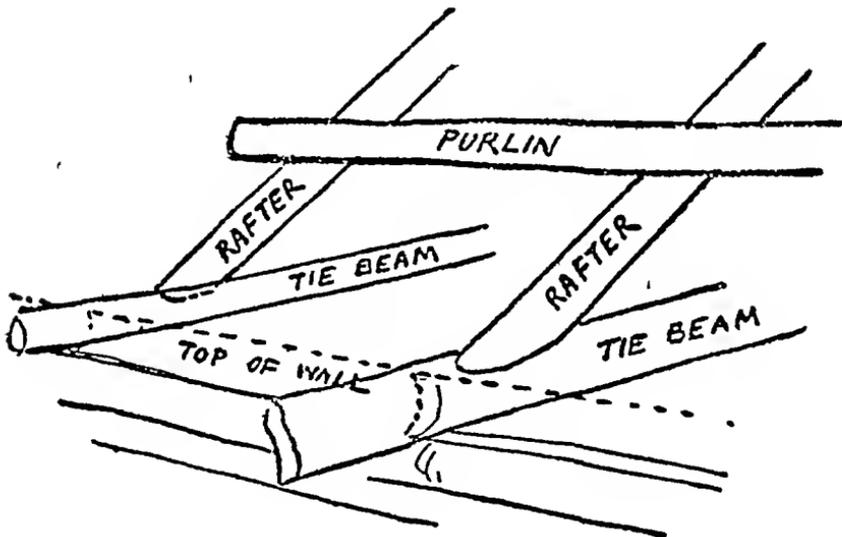

Fig 74

It is now necessary to fix the purlins. These should be of thinner material and as long as possible. They have to be sunk slightly into the rafters to maintain the slope of the roof, as otherwise it will look like a piece of corrugated iron.

The triangular ends between the top of the end walls and the

PIONEERING

roof have now, to be filled in. The logs for these are laid, caulked and spiked as before, but they have to be so cut at their ends that they maintain the exact line of the rafters. For this purpose some kind of a straight-edge must be used, running if possible from the ridge down to the walls.

Covering the Roof

It now remains to cover in the roof. Boards are first laid across the purlins running from ridge to wall, and projecting past the walls as far as desired. It is a good plan to break the straight line and modify the slope of the eaves so that it is not quite so steep as that of the rest of the roof. The best kind of board to use is elm, pine will do but it does not look so well. It is better if the boards are of varying widths, so that too uniform an appearance is avoided. In fastening on the boards care should be taken not to fit them too closely together, but

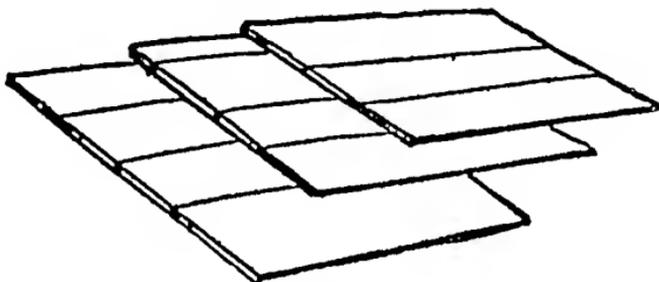

Fig 75

to keep them level. It may be necessary sometimes to trim the purlins and to make slight adjustments here and there.

On top of the boards some kind of weather-proof material, such as one-ply rubberoid or something similar, should be fixed.

Then comes the question of the final finish of the roof, the materials for which will, of course, have been collected beforehand.

If shingles, or shakes, are used the best kind to get is cedar, but oak can be also used. Oak shingles should, however, be soaked in boiled linseed oil first. Shakes are about three feet long and are fixed in exactly the same way as shingles, galvanised nails being used. The method of laying shingles is illustrated in Fig 75, the overlapping being very important. To ascertain how many shingles or shakes will be required, cut some pieces of paper to the size obtainable, and find by experiment how many will be needed to cover a square yard. The cedar shingles for the Gidney Log Cabin were obtained from Canada at a cost of about £12, including transport.

It will be necessary to put a ridge-beam at the top to prevent rain getting down under the shingles. The ridge-beam will probably have to be jointed, and rubberoid or other similar material should be put under the joints. A V-shaped groove fitting on to the roof has to be cut out of the beam, which is spiked down on to the rafters.

In Scandinavian countries another method of covering the roof is used. Vertical boards are fixed round the eaves and at the ends, making a kind of tray. The foundation boards are covered with very thick waterproof material and then tarred. It is interesting to note that in Scandinavian countries birch-bark is used for this purpose. The tray is then filled with mould and sown with grass.

Laying the Floor

The flooring of the interior can be of beaten earth, but this is very unsatisfactory, especially in wet weather. If there is a concrete or cement foundation all over, tongued and grooved boards should be laid on this after a thick coating of tar has been painted on the concrete.

If there is no concrete floor foundation, the best method is to lay a double flooring. The floor is first covered with one lot of boards, well creosoted, and on top of them a layer of tar-paper or other material is placed. The second lot of boards is now nailed on at right angles to the first lot.

In any case the surface of the floor should be treated with creosote or solignum.

Fittings and Decorations

The fittings of windows and doors look best if made of hand-forged iron by a blacksmith, and should be of the simplest character.

Nothing should be put into the cabin that would clash with its backwoods appearance. Antlers, etc., look well on the walls, or weapons and tools that one would associate with the backwoodsman. The furniture should be as simple as possible, but of stout construction. A good deal of this can be home-made, but so-called "rustic" furniture should be avoided.

The difficulties of trying to compress into a single chapter a description of the building of a log cabin will be apparent. During the erection all kinds of little problems will have to be settled by rule of thumb and the same principles of building apply to the cabin or shelter, and a good deal of w

PIONEERING

can be applied with the necessary modifications to the building of less ambitious structures. It is necessary always to have some one person definitely in charge who is recognised as the one authority to make decisions. When work is in progress it should be done by gangs each under its leader, and all concerned must be ready to obey orders and do as they are told. In work of this kind there are limitless opportunities for the inculcating of good qualities in the way of discipline, team spirit, patience, hard work and so on into Scouts, Rover Scouts and Scouters. We can all benefit thereby.

CHAPTER XVIII

THE RESULTS

“The principles on which Scouting works is that the boy's ideas are studied, and he is encouraged to educate himself instead of being instructed” (*Scouting for Boys*)

THE purpose of this book has been to suggest to Scouters mainly ways and means by which they can interest Scouts and Rover Scouts in the subject of pioneering, and to show them in part the varieties of practices that can be indulged in.

Those who make any attempt to work out these suggestions will soon see that both boys and men are interested in these things, and are willing to apply themselves to them. Once a start has been made it will be found that a Scout Troop or a Rover Scout Crew will want to go on and do more, and in this way “the principle on which Scouting works” becomes an accepted part of our training.

As progress is made the Scoutmaster or the Rover Scout Leader will find that he is able to retire more into the background, and to occupy himself not with doing things for himself, but with watching how the others do them. We Scouters do not take very kindly to that, we want to be at it ourselves, yet it is essential that we should from time to time stand aside and watch. In this way the Scoutmaster gets really to grips with the character of his Scouts. He sees who are the leaders, who do the work, who merely look on, who are competent to tie knots and lashings, who can suggest ways and means of circumventing an unexpected difficulty, who have the application to stick to a job until it is done, and who quickly tire. He can judge of the abilities of his Patrol Leaders, and of their

powers of leadership. Above all he can judge the spirit of the Troop as a whole and of the individual Scouts in it

In these and other ways he can be doing the job which is all important—Preparing the Way of his Scouts so that they can become real men

There is no need to stress this point. The important result of pioneering practices is not the ability to erect bridges, towers and shelters, but the effect it has on the characters of the Scouts

The question of gear may be a problem, but it is a problem which any normal Scout Group can overcome. Scout staffs and light lashings are sufficient for a start, and gradually ropes and blocks and spars can be acquired bit by bit. There is no need to launch out and procure an elaborate set of gear straight away. Half the fun of the game lies in improvisation and in making good use of what little one has. If we have too much gear, the game degenerates into a drill, and the boy's idea in regard to it all is lost sight of. Later on the Scouts themselves will want to work with more material as they themselves become more ambitious, then is the time to set about procuring it by loan or purchase

Incidentally Local Associations can be of great service to the Scout Groups in their area by laying in an Association stock of spars, ropes, blocks and tackle and other things which their Groups can have the use of. In this way a Local Association can fulfil its function of encouraging Scouting in its area

If any Scout Group has the *will* to do Scouting, and to take up such an activity as pioneering that will further its Scouting, the *way* will not be too difficult

Of set purpose no very clear distinction has been made between Scouts and Rover Scouts in regard to the various practices suggested, although the point has been alluded to here and there. Of necessity the distinctions to be drawn depend very much on local circumstances, and upon what the Scouts have themselves done, or are doing, in the Group or the Association. We can, however, be quite certain in our minds that there are in this subject plenty of opportunities for Rover Scouts to indulge in practical Scouting, opportunities which will benefit them immensely in other directions as well. Backwoodsmen, explorers, frontiersmen, pioneers, all were real men, and there is much that can be learnt by the men of to-day from the kinds of things that they did

The Scouter himself must realise that it is not essential to be an expert in these matters before one can take them up. There is no reason why he should not learn by experiment along with his Scouts and Rover Scouts. If he is very doubtful

PIONEERING

of himself and of them, then he should look round in the neighbourhood for someone who can tell them a thing or two, and the laws of averages are such that some man who knows a bit about pioneering is usually available when wanted. The real dangers that lie in any practice have been mentioned. They can be easily guarded against. For the rest a certain amount of risk is a necessity in the training of manhood.

“Quit you like men, be strong”

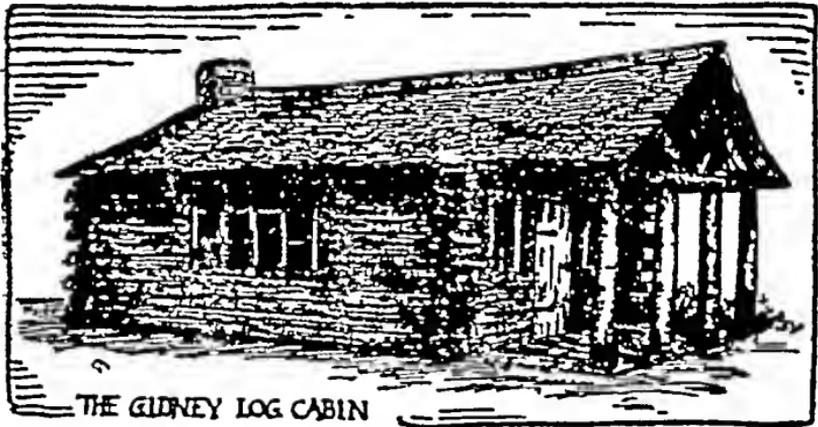

INDEX

A
 Aerial runway, 48-50
 Anchorages, 34-35
 Axémanship safety rules, 106-107
 Axes—
 Care of, 104
 How to use, 107
 Types of, 103
 Using, 105

B
 Barrel sling, 24
 Billhooks, 103
 Blocks, 29-30
 Prices, 30
 Bosun's chair, 25-26
 Bridge—
 Catamaran, 60
 Choosing site of, 61-63
 Double lock, 66
 Ladder, 57
 Lariat and staff, 53
 Light pole, 57-59
 Log, 56
 Monkey, 50-53
 Scout staff, 55
 Single lock, 66
 Trestle, 62-64
 Bridges, light, 54-60

C
 Camp shelters, 83-89
 Cant-hook, 28
 Catamaran foot-bridge, 60
 Raft, 45-46
 Character training, 9
 Clearing up, 12
 Climbing, 76-77
 Apparatus, 77
 Ladders, 78-79
 Ropes, 78
 Coiling ropes, 15-16
 Coracle, 40-41
 Cordage, 13-15
 Crate raft, 41

D
 Diagonal lashing, 20-21
 Dining shelters, 88-89
 Displays, 89-94
 Competitions for, 92-94
 Indoor, 91

Displays (*continued*)—
 Outdoor, 92
 Practice for, 94
 Double lock bridge, 66-67

F
 Figure-of-eight lashing, 21-22
 Flagstaffs, camp, 68-70

G
 Glossary, 7

H
 Holdfasts, 34-35
 Hurdles, 87
 Huts, 87

I
 Instructional models, 94-95

K
 Kitchen shelters, 87-88
 Knives, 103
 Knotting boards, 95

L
 Ladder bridge, 57
 Ladders, climbing, 78-79
 Lariat and staff bridge, 53-54
 Lashing block to spar, 22
 Lashings, 19-24
 Lever spars, 38
 Levers, 27-28
 Levering up pegs, 39
 Light pole bridge, 57-59
 Lob line, 46-47
 Lock bridges, 65-67
 Log and picket holdfast, 35
 Log bridges, 56
 Log cabin—
 Building, 109-120
 Decorations, 119
 Fireplace, 113
 Fittings, 119
 Floor, 119
 Foundations, 113
 Materials for, 110, 112
 Roof, 116-119
 Log raft, 42

M
 Mallets, 101
 Malvern tower, 76

INDEX

- Marline hitch, 23-24
- Masts, signalling, 70-71
- Materials—
 - For log cabin, 110, 112
 - For models, 95-96
 - To cut, 108-109
- Mauls, 101
- Models, 94-100
 - Building, 98-99
 - Materials for, 95-96
 - Scale, 96
 - Monkey bridge, 50-53

N

- Neolithic dwellings, 84

O

- Observation, 10

P

- Parbuckle, 28
- Petrol-tin raft, 44-45
- Pickets, removing, 39
- Picks, 101
- Pioneer's tools, 100-105
- Pulling a rope, 32-33

R

- Rafts, 39-47
- Rallies, 89-94
 - Outdoor, 92
- Reeving blocks, 29
- Relieving a strain, 32
- Results, the, 120-122
- River-bed, 62
 - Current, 63
- Roof, for log cabin, 116-119
- Rope tackle, 32
- Ropes, 13-19
 - Care of, 15
 - Coiling, 15-16
 - Lay of, 14
 - Re-laying, 16-17
 - Storing, 16
 - Straining, 30-33
- Ropeways, 47-54
- Round turn, using, 33
- Runway, aerial, 48-50

S

- Sack sling, 24
- Safety, rules of axeman'ship, 106-107

- Sailmaker's whipping, 17-18
- Sails, 47
- Sausage raft, 42-44
- Saws, 102
- Scale of models, 96
- Scout—
 - Staff tower, 73-76
 - Staffs, 55
 - Transporter, 59-60
- Securing rope to hook, 23-24
- Selvagee, 23
- Sheer-lashing, 21
- Sheer-Legs, 34-39
- Shelters—
 - Camp, 83-89
 - Dining, 88
 - Kitchen, 87-88
 - Simple, 86
 - Tree-top, 80-83
- Shovels, 101
- Signal tower, 71-73
- Signalling masts, 70-71
- Single lock bridge, 66
- Slings, 26-27
- Spades, 101
- Spanish windlass, 31
- Square lashing, 19-20
- Storing ropes, 16
- Straining ropes, 30-33

T

- Tackle, blocks and, 29
 - Rope, 32
- 3-2-1 holdfast, 34-35
- Tools, pioneer's, 100-105
- Tower—
 - Malvern, 76
 - Scout staff, 73-76
 - Signal, 71-73
- Towing lines, 46
- Transporter, 59-60
- Tree dwellings, 83
- Tree-top shelters, 80-83
- Trestle—
 - Calculating measurements, 63
 - Constructing, 64
 - Launching, 64
 - Parts of 61

W

- Weights, moving heavy, 27-30
- Whipping, sailmaker's, 17-18
- Wind-breaks, 84, 86